

save our seas

THE SAVE OUR SEAS FOUNDATION MAGAZINE



STORYTELLING | PEOPLE | IMPACT

EDITOR'S LETTER

Last year, the conservation world lost one of its titans. For many, Jane Goodall was the first example of an individual trying to understand wild animals. Her capacity for empathy and understanding seemed to know no bounds. This enabled Jane to forge a path in a space incorporating both science and storytelling. A path that many had believed impossible. Jane passed away while an all-female team of science communicators were putting this storytelling issue of the *Save Our Seas* magazine together, and it is with her in mind, and great pride, that we share this special issue with you.

With a focus on storytelling, it features stories from locations around the globe: stories about inspiring individuals and their study species, stories about communities, stories of hope, stories that connect us. And stories brought to you by the recipients of our Ocean Storytelling Grant.

Our photography grant winners – Shane Gross, Gabriella Angotti-Jones, Sarang Naik and Acacia Johnson – share powerful stories from remote islands in Seychelles, vibrant coastal communities in Ghana and Cameroon, the often overlooked intertidal zones of Mumbai and South Africa's Wild Coast, and the sage fishers of the Yucatán Peninsula in Mexico.

The winners of our writing grant – Wenzel Pinto, Dimuthu Attheyake and Fanni Szakál – journeyed to Cameroon to profile one of the region's conservation leaders; to French Polynesia to explore the effects of climate change on shark pups; and to Gqeberha to investigate why the man-made Port of Ngqura in South Africa has a higher abundance of fish than anywhere else along this coastline.

As always, it was inspiring to have our Director of Storytelling and *National Geographic* Photographer and Explorer, Tom Peschak, chat with Lauren De Vos about the importance of impact-driven storytelling. Dr Dylan McGarry, educational sociologist and cultural ecologist, shares valuable insights into some of the pitfalls conservation storytelling can fall into and the need for a change in approach. And Noel Kok, co-founder of Nature, Environment & Wildlife Filmmakers (NEWF), shares how he's creating a more equitable global platform for Africa's storytellers while also fostering a strong, connected community.

In the spirit of *ubuntu* that guided this issue, we hope you enjoy these stories and their characters, the dedicated researchers, the species they are working to protect, the writers, the photographers, the opinions. And let's celebrate the conservation storytelling that has brought us all together.

Jade Schultz

Jade Schultz
Editor-in-Chief



CONTENTS

INTRO

Editor's Letter	3
Contributors	6
Who is the SOSF?	8

Q & A STORYTELLING

Thomas Peschak	10
----------------	----



PHOTO PORTFOLIO

Room to Breathe	
Shane Gross	18



FEATURE STORIES

Shark Pups Show the Way	36
Coastal Connections	44
Accidental Shark Sanctuary	66
Intertidal Impact	74
Shaping Marine Conservation in Cameroon	88
The World Changes, and We Don't Remember	96

OPINION PIECE

Nothing Comes Without its World	116
------------------------------------	-----

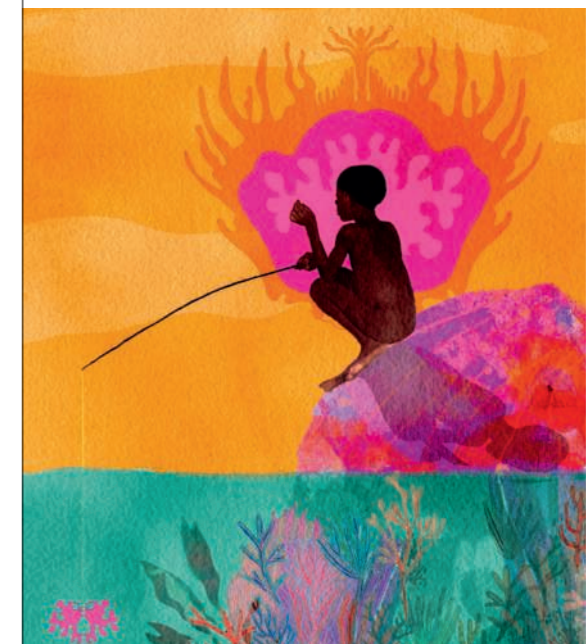

FROM THE FIELD

Africa Refocused	122
---------------------	-----

Contributors



GABRIELLA ANGOTTI-JONES

OCEAN STORYTELLING
PHOTOGRAPHY GRANT WINNER

Inspired by those who use their relationship with the ocean to help raise awareness about conservation, Gabriella aims to continue highlighting communities whose identities intertwine with the sea. She's based in Los Angeles and shares stories of those acclimatising to our rapidly changing environment.



DR LAUREN DE VOS

SCIENTIFIC WRITER

Cape Town-based Lauren was a marine biologist before fully committing to conservation storytelling. She wants to flood our media with reminders of a natural world that many of us are becoming increasingly disconnected from and to share the visions of the world so many people are committed to building, nudging us back to caring for each other and our planet.



ACACIA JOHNSON

OCEAN STORYTELLING
PHOTOGRAPHY GRANT WINNER

Acacia hails from Anchorage and is working to build a career that makes a genuinely positive impact on environmental initiatives and decision-making. Photography is often used as a window into a subject, but she wants to find a broader use for her images and storytelling in action-oriented initiatives that go beyond photojournalism alone.



DIMUTHU ATTANAYAKE

OCEAN STORYTELLING
WRITING GRANT WINNER

Dimuthu chose journalism to bring about a positive impact to the society and the environment she lives in. She hails from Sri Lanka and believes that journalism works as a powerful tool not only to bring to light conservation issues that the public and policy-makers know little about, but also to advocate for change.



SHANE GROSS

OCEAN STORYTELLING
PHOTOGRAPHY GRANT WINNER

On a mission to save the world, British Columbia native Shane hopes to continue making a living doing work that he believes in: supporting scientists, conservationists and fellow storytellers. Knowing he'll be doing this for the rest of his life, all he hopes is that his health and circumstances allow it to be a long one.



SARANG NAIK

OCEAN STORYTELLING
PHOTOGRAPHY GRANT WINNER

Mumbai-based Sarang's goal is to tell stories that ignite a spark of curiosity and wonder in others. Working with conservation and research organisations, he wants to share the stories of India's coastal, tribal and rural communities that have been consistently, and often violently, excluded from the conservation dialogue.



DR DYLAN MCGARRY

EDUCATIONAL SOCIOLOGIST, CULTURAL
ECOLOGIST, MULTI-MEDIA ARTIST

Cape Town-based Dyl works as an educational sociologist, cultural ecologist, multi-media artist, activist, curator and theatre- and filmmaker. As co-founder of Empatheatre, their work draws on the power of public storytelling for regenerative community-building, pro-active justice, active empathy, meaning-making and fostering inclusive forms of governance in complex social-ecological entanglements.



FANNI DANIELLA SZAKÁL

OCEAN STORYTELLING
WRITING GRANT WINNER

Fanni is from Hungary and likes to highlight stories that don't usually make it into the media. In addition to reporting on lesser-known animals and conservation issues, she is interested in showing how the fate of nature is intertwined with ours and in bringing stories from under-represented communities to light.



THOMAS PESCHAK

DIRECTOR OF
STORYTELLING

Thomas swapped marine biology for photojournalism when he realised that his photographs could create more powerful and immediate conservation change. He has spent 20 years documenting the beauty and fragility of our oceans, islands, rivers and coastlines for *National Geographic* and continues to be a pioneer in the field of impact-driven storytelling.



WENZEL PINTO

OCEAN STORYTELLING
WRITING GRANT WINNER

Wenzel weaves scientific studies and facts into a story format and draws on his own experiences to make scientific knowledge more digestible and enjoyable for everyday readers with no previous interest in wildlife or conservation. Working in Lakshadweep archipelago off India's west coast, he focuses on understanding the potential of lagoons to act as climate change refugia for the outer reef.

WHO IS THE SOSF?

RESEARCH
EDUCATION
CONSERVATION



Since its inception in 2003, the Save Our Seas Foundation has funded 605 projects in more than 100 countries worldwide and has remained on the pulse of current research, conservation and education projects that focus on sharks and rays

605 PROJECTS SINCE 2003

5 LONG-TERM PARTNERS

- Shark Spotters
- The Acoustic Tracking Array Platform

- The Manta Trust
- Cape Eleuthera Institute
- North Coast Cetacean Society

58.3% of species targeted by funded projects are threatened with extinction

252
SHARKS & RAYS



12
MARINE MAMMALS



SPECIES FUNDED

8
SEA TURTLES



7
CHIMAERAS



48.2%
MEN



51.8%
WOMEN

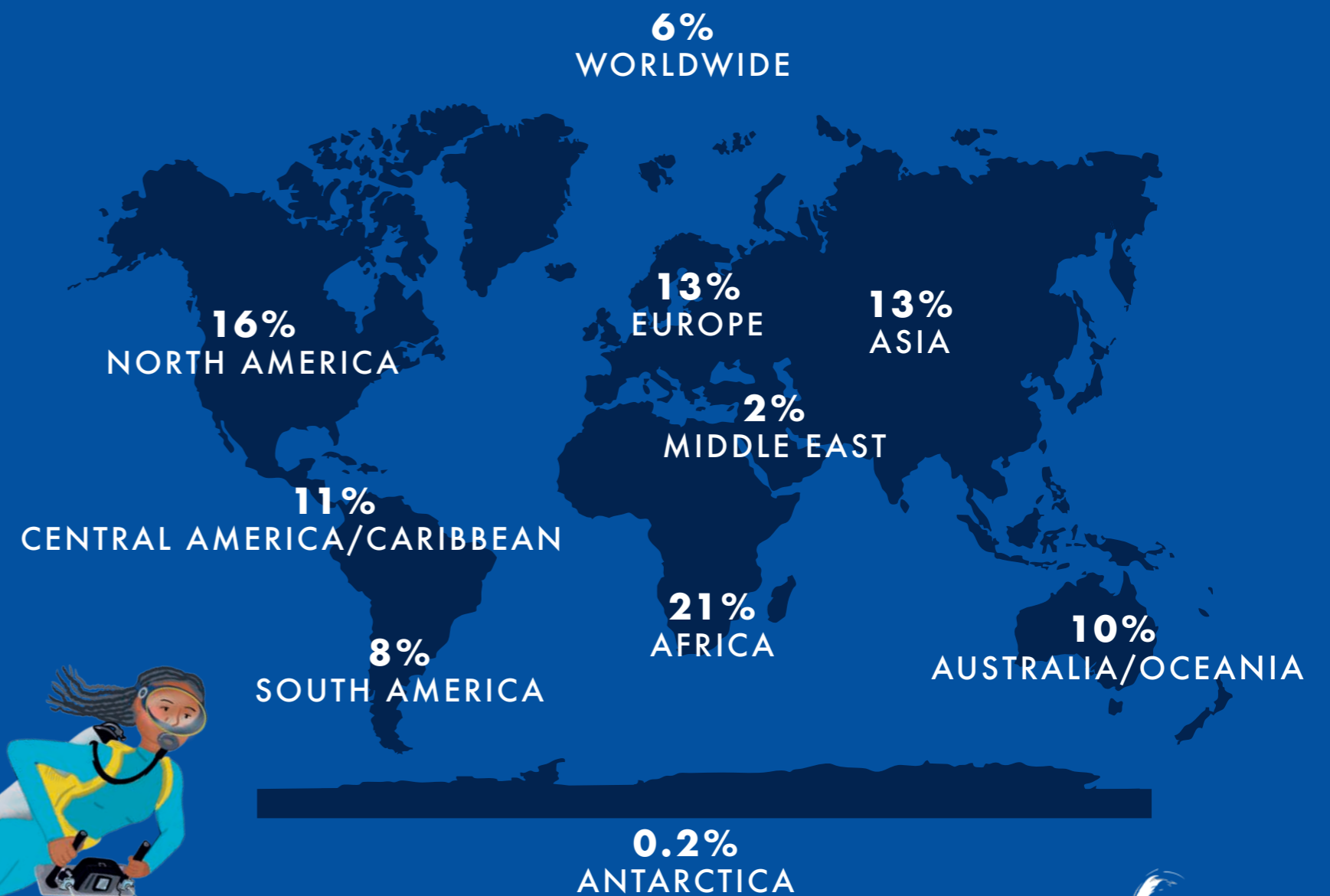
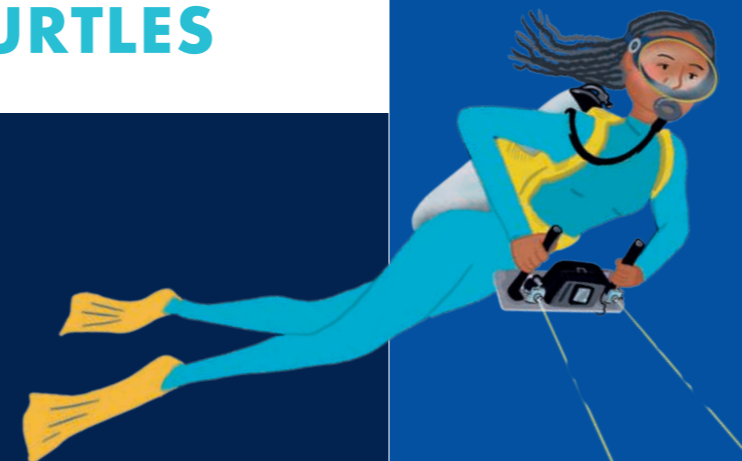



© Daniel Ziegert

Q & A

Thomas Peschak

How to have impact

Thomas Peschak has spent more than 20 years bringing stories about our oceans and rivers – their beauty, their importance and the scale of our impact on them – as a *National Geographic* Photographer and Explorer and as the Save Our Seas Foundation Director of Storytelling to audiences across the planet. Lauren De Vos chatted to him about impact-driven conservation storytelling and the urgency of crafting stories to catalyse change.



Top: Mice, introduced to sub-Antarctic Marion Island 200 years ago, flourish on a diet that now includes live albatrosses. This scalped grey-headed albatross chick has no instinctual fear of this new danger and sits passively while being slowly nibbled to death.

Storytelling is as old as our species. What is its relevance today and what is especially important about conservation storytelling?

There's storytelling for pleasure and storytelling for impact. We have been telling stories for hundreds of thousands of years and, initially, probably to modify our behaviour for survival. Whether we were recounting stories from a hunt or warning about the great monster that lives deep in a river, stories helped us to learn about each other and the world, and to teach the next generation how to survive. Then we had a moment in history where we could follow a storytelling model largely for pleasure: action films, science-fiction books, cartoons and comedies. Sure, some of them translated morals, taught us something or incorporated commentary. But a lot was purely escapism. Even the natural history genre told stories of exploration and wonder, and while we can learn a lot from these, there's no real incentive to change anything about how we're living on this planet. Now we need to tell conservation stories that will make us change our behaviour to ensure our survival.

All cultures have stories that connect us and nature, but in modern natural history storytelling, some storytellers, like Rachel Carson, are synonymous with changing the conservation storytelling landscape, whereas others – Jacques Cousteau and David Attenborough, for example – incorporated conservation much later into their work. How has the urgency of storytelling changed?

We've moved on from being able to share just for 'raising awareness'; we're at the edge of catastrophe. Today when we tell stories, we need to be able to measure what that story has done to bring about change. I think that 95% of the natural history media that is out there now and rides on the premise of raising awareness – whether it's content published by influencers or major networks – has little measurable impact on conservation action.

Conservation science emerged as a 'subgenre' of science in the 1970s; it's science for change. But conservation storytelling is similarly emerging far more recently from natural history storytelling. How is the process different from what's been done before?

Conservation storytellers must be highly strategic. If you're a conservation storyteller – whether you're a photographer, writer, podcaster or filmmaker – you must ask a few questions whenever you encounter a story. The first of these is: who do I need to tell this story to? Who is my audience? And then, what is the scale and scope of my story? Do I need to reach one hundred million people to create a groundswell of change or do I have to reach one politician?

I think very few people are without ego, and most of us want to reach an audience of one hundred million. Sometimes that can achieve two things: it can tell a powerful conservation story and it can hit all the right personal dopamine buttons. While I think everyone's hearts are in the right place, we have to critically interrogate what we want to achieve. Audience size can be deceptive, so as a conservation storyteller you need to accept that most people might never see your story. If you achieve your conservation goal, then you've fulfilled your purpose more fundamentally than if you've reached a huge audience or been published by the biggest names in the industry.



Collecting olive ridley eggs - during a permitted window - at Ostional, Costa Rica, where the arrival of these turtles heralds dense overcrowding. The turtles nest so close together that they inadvertently crush one another's eggs.

Conservation storytellers come from different walks of life. I come from a science background, which means I've always had to measure my impact. But there are so many different pathways into this, and I think that our future will rely on teaching strategy and impact evaluation as part of the conservation storytelling craft.

We live in a media moment where online visibility is driven by algorithms and 'going viral'. How hard is it to make highly strategic conservation communication economically viable?

It is very hard to convince funders to support this kind of impact-oriented media. Making a living as a natural history photographer, or an environmental photojournalist, is difficult. This is true even if you're not considering a conservation message. There are very few people today who are making a living exclusively from that; most have to run photographic tours or wildlife safaris, or create any number of other income-generating endeavours to make a living while taking photos of wildlife. Most people you see online are making a living another way.

We have to amplify conservation storytelling if we are going to drive the change we need to fix our planetary crises, but how do we find money to tell conservation stories?

The role of most media outlets is not to drive environmental change; it's to sell stories. This is where philanthropy and NGOs come in. By definition, the mandate of charities and non-profit organisations is to push for change and try to repair whatever is broken. But while there is some funding out there for conservation storytelling specifically, we are right at the beginning of it all.

We have had decades of funding for science and then for conservation, but in the past 20 years we've introduced this conservation storytelling tool that's very much in its infancy. When we look at the percentage of funding that's directed to conservation science versus conservation storytelling, it's unequal. So we need to educate the media, philanthropists and people who want to make a difference. Yes, we need science; it's important. We need data to understand how our world is changing, but data alone no longer move the needle. We need to pair the science with innovative, iconic and moving storytelling. When we can raise the profile of storytelling and raise its funding to the point where science and storytelling are equal, only then will we create more opportunities for conservation storytelling professionals.

I want to become a conservation storyteller. Where should I begin?

If you have the right skill set, passion, temperament – there is a possibility that you might make a living from telling conservation stories. But the odds are stacked against you.

With that in mind, it's worth knowing that as a storyteller at the beginning of your career, you might not be able to do conservation storytelling exclusively for the first decade or so. You first need to cut your teeth in a lot of different ways. You have to find your voice and figure out what makes your stories – and your way of telling them – different from anybody else's. In many ways, you spend your 20s and 30s learning and figuring out how to tell stories; it's about reading and meeting like-minded people and listening. Storytelling is something that you get better at the more you do it and the more experience you gain. You won't be fully formed in your 20s. A lot of photographers at *National Geographic* peaked in their 50s; they created their most powerful work after practising their craft for more than 30 years.



Top: This inquisitive northern elephant seal pup is evidence of a comeback; a century ago, any curiosity would have been met with bloodshed. Elephant seals were hunted for their blubber and teetered towards extinction in the late 19th century.



Bottom: Two marine iguanas in Galápagos – alert, alive – and their mummified brethren (left) that probably died of starvation.



What role can people across the conservation sector play?

There are any number of highly qualified people who are perfectly positioned to share stories and who are already embedded in networks of conservation expertise and influence, who could benefit from some training in crafting and telling the stories they already carry. Obviously, it would be ideal to have a large group of expert storytellers able to do this full time. But what about the conservation scientists? What about the environmental lawyers? You don't need to be a full-time storyteller to make a difference in the storytelling field. We need to look at training people who are already making a living in the environmental space to become better storytellers. And while they might never reach the level of a 20-year professional career with *National Geographic*, you don't always need *National Geographic*-level content. You can often push the needle with something that might look and feel quite modest.

There is an international audience that most storytellers want to reach, but we also need local voices who tell powerful stories. Do you think we're making progress in achieving pathways to both?

We've made gigantic strides. If you just look at the Save Our Seas Foundation Storytelling Grant and how the diversity of winners, and the stories they're telling, have changed, you can see that the days of having only North American, European or Australian ocean storytellers are gone. The trick is in finding a balance. We urgently need more local storytellers on the ground to tell stories in their 'backyards'. But we also need people to travel halfway across the world because there is something powerful about getting a fresh perspective. When you have decades of international experience and a truly global perspective on a story, you can often find angles and nuances that others might miss. There are, of course, also situations where a much-needed storytelling skill (underwater photography, camera trapping, etc.) might not be available at a certain geographical location. In that case, flying in a storyteller might be the only option, but this should be paired with on-the-ground skill transfers and subsequent mentorship. I think that as long as we have a healthy balance between both those approaches, we're moving in the right direction.

There are opportunities to support emerging storytellers, but how should that reshape the industry?

There needs to be fairness in opportunities and expectations. We've trained many storytellers now from South America and Africa, and it's fair for them to ask: 'Hang on, you'll only support and fund me if I stay and tell stories in my home country?' There should be pathways for these storytellers to spread their wings too. A storyteller from Ghana needs to have the opportunity to go and tell a story in Ecuador. Just because you received a grant to tell your story in Indonesia, shouldn't mean - if you're a talented, hardworking storyteller - that you have to do that for the rest of your life because funders have become too focused on only ticking the 'local storyteller' box. I think it's important that storytellers are able to access both local and global pathways. From a conservation perspective, it is also important to assess which approach is likely to result in the greater impact.

In our increasingly digital world, where should we be placing our efforts to meet our audiences?

This is where we need to again focus on strategy and mindfulness. Who is your audience and what is your intention? Is this a virtual reality experience, a photographic exhibit in a public space, a slideshow for the president or a film to move the masses? Social media can be problematic: we're drowning in content. Some of it is packaged as conservation storytelling, but in reality all it often does is sustain the creator's lifestyle and ego - and what's the conservation impact of that? We often label this content noise as 'raising awareness' - and, to a degree, it's great to see so much natural history content available - but we risk flooding out messages about urgent conservation work that often look less aspirational. I don't know what the solution is here: everyone has the right to do what they want, but I do think that some curation is needed. That's why I don't believe that social media is always the best way to tell a conservation story. Traditionally, there has been 'gate-keeping' in the media world - and this can be really harmful and unhelpful. But there is also a case to be made for editorial oversight, the benefit of curation and the prioritisation of expertise to craft accurate, high-quality stories, whether the storytelling is in print, on screens or in person.

Where do you want to place your own conservation impact?

Of course, it's amazing when you can photograph a huge *National Geographic* story and drive measurable change and impact. But that cannot be the only way. That type of storytelling can sustain, at the most, fewer than a dozen full-time professionals. We can't have just 10 people telling this type of story when we are fast approaching environmental Armageddon. My personal drive now is to ask, how do we create an army of storytellers around the world? How do we train hundreds, if not thousands, of scientists, lawyers, journalists and others in the crafting of conservation stories? It means having to be realistic about the number of full-time professionals who can operate at the highest levels of conservation storytelling. And it means understanding that the bulk of immediate, urgent conservation victories need to be tackled and won by people who are already firmly established in other conservation-adjacent spaces.



Top: A Critically Endangered great hammerhead, caught off Oman's remote Musandam Peninsula, awaits transport to the Dubai fish market.

Bottom: Mining for guano - nutrient-rich seabird droppings - in the 19th century sent Peru's seabird populations into freefall. Overfishing, climate change and the resulting lack of food have now seen the pelicans that once nested in their hundreds of thousands all but disappear.

A large tortoise, likely a Galapagos tortoise, is shown in profile on a sandy beach. The tortoise's head and neck are extended towards the right, looking out at the ocean. The background features a cloudy sky and waves breaking on the shore. The overall tone is somber due to the overcast sky.

ROOM TO BREATHE

Shane Gross

OCEAN STORYTELLING PHOTOGRAPHY GRANT WINNER

At over 100 years old, Petits Fours lords it over D'Arros Island, the territory that he and others like him acquired when they were re-introduced from Aldabra to other Seychelles islands.

Protecting biodiversity supports ocean health. The condition of shark pups that grow in St Joseph Atoll's protected waters, for instance, is better than that of pups growing up in more degraded coastal systems.



D'Arros Island and St Joseph Atoll are a fish diversity hotspot, where more than 497 bony fish species (like these giant trevallies) have been recorded, as well as some 17 shark and ray species. This accounts for nearly two-thirds of all reef-associated fish in Seychelles.



The near-pristine condition of D'Arros and St Joseph Atoll harbours wildness on a grand scale, from tiny crabs to baleen titans.



A B O U T

'How do you take a story that you want to tell and show it through still photographs? There's a bit of magic involved there, I think.' Shane Gross travelled to D'Arros Island and St Joseph Atoll to document one of the earth's last living laboratories. 'I want to get as close to the truth as possible,' he says. And while many beautiful images of this tropical paradise have been taken before, a conservation story must hint at an ugly truth: life on our planet is in peril and near-pristine places like D'Arros Island and St Joseph Atoll are disappearing. 'It's about trying to make an image that is somewhat different, so that people will pause for a second and try to figure it out. The more time they spend with something, the more opportunity you have to persuade them of an idea and make them feel something about how we need to change.'

Peppered moray eels emerge from pools and slither over the rocks to hunt in the intertidal zone.





Research life on D'Arros Island is nothing if not varied: a changing climate, encroaching pollution and overfishing all need monitoring. Working on St Joseph Atoll (bottom, left) often means camping in high temperatures and humidity, among clouds of mosquitoes.





D'Arros and St Joseph is one of the most important areas in the Western Indian Ocean for the Critically Endangered hawksbill turtle and for the green turtle, which has recently been down-listed to Least Concern.

The declaration of marine protected areas like D'Arros helped Seychelles achieve 30% protection of its ocean.

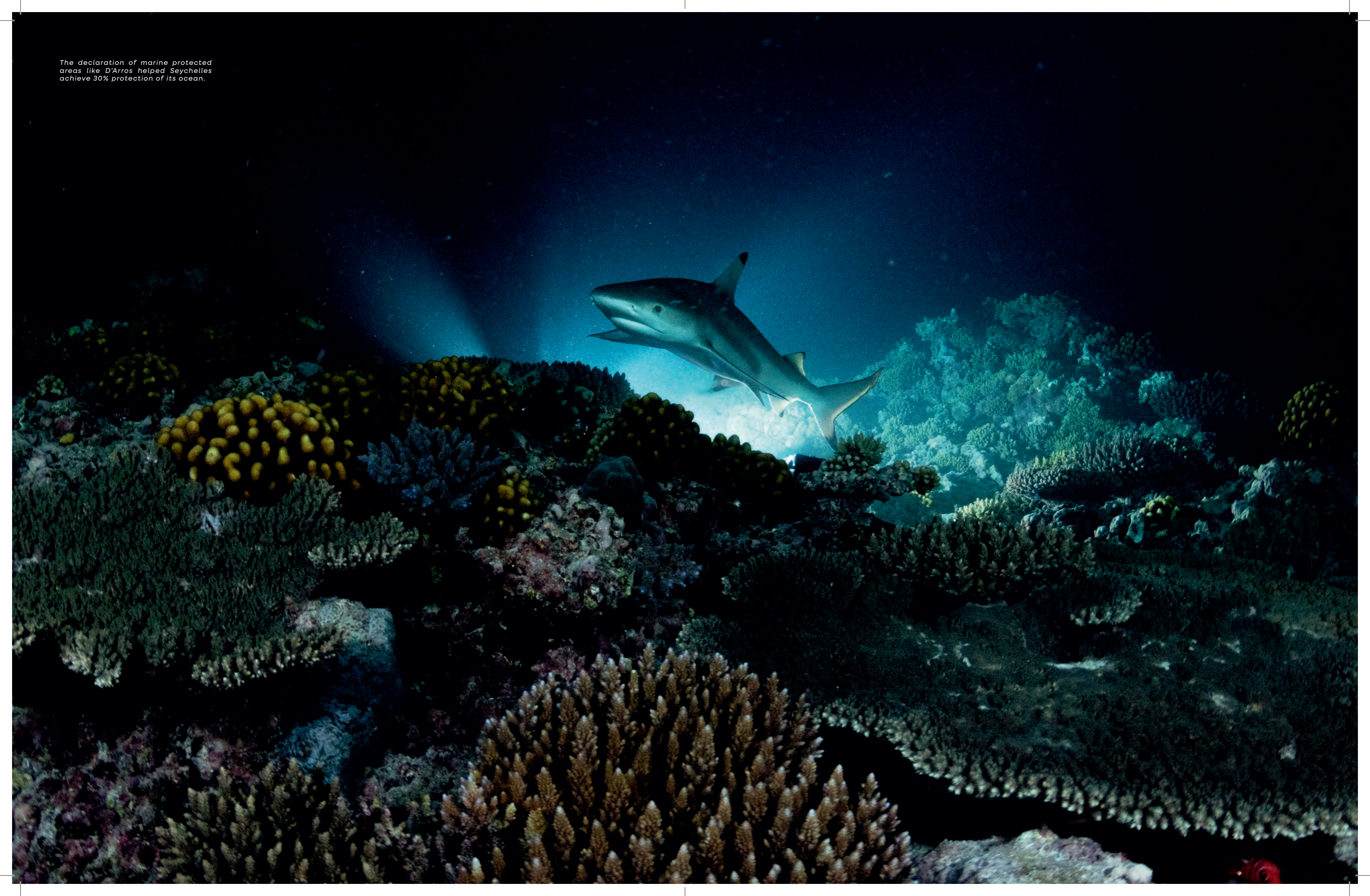

Reef mantas are important distributors of nutrients across coral reefs. As of May 2025, more than 500 individuals have been identified in Seychelles.



Shark pups show the way

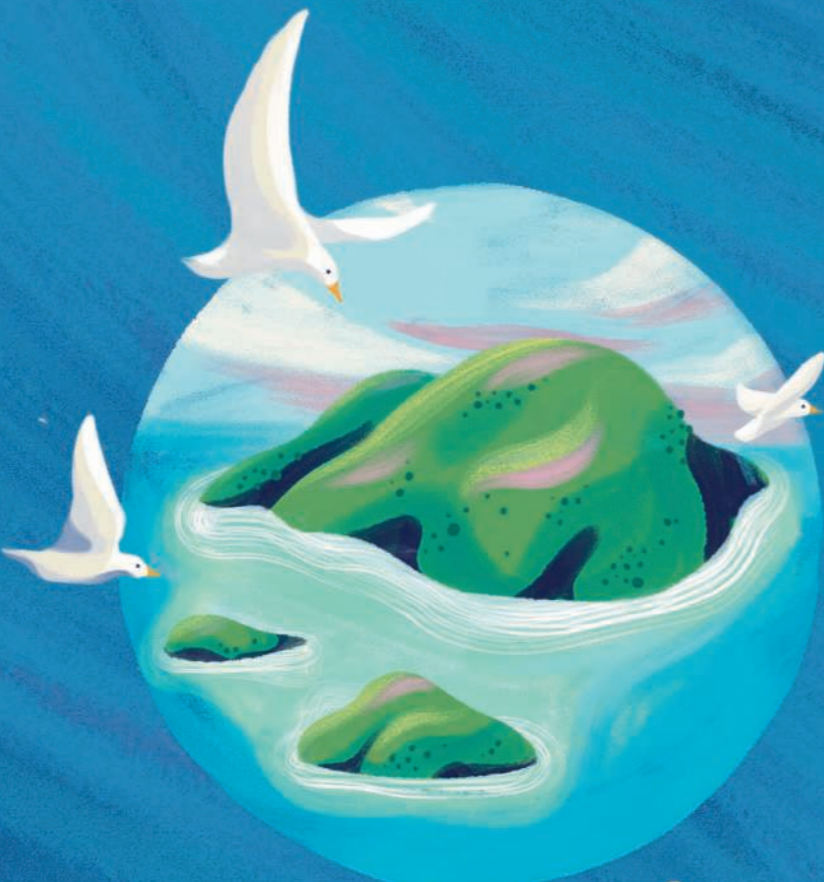

MOO'REA
French
Polynesia

South
America

Australia

New
Zealand

SOUTH PACIFIC
OCEAN



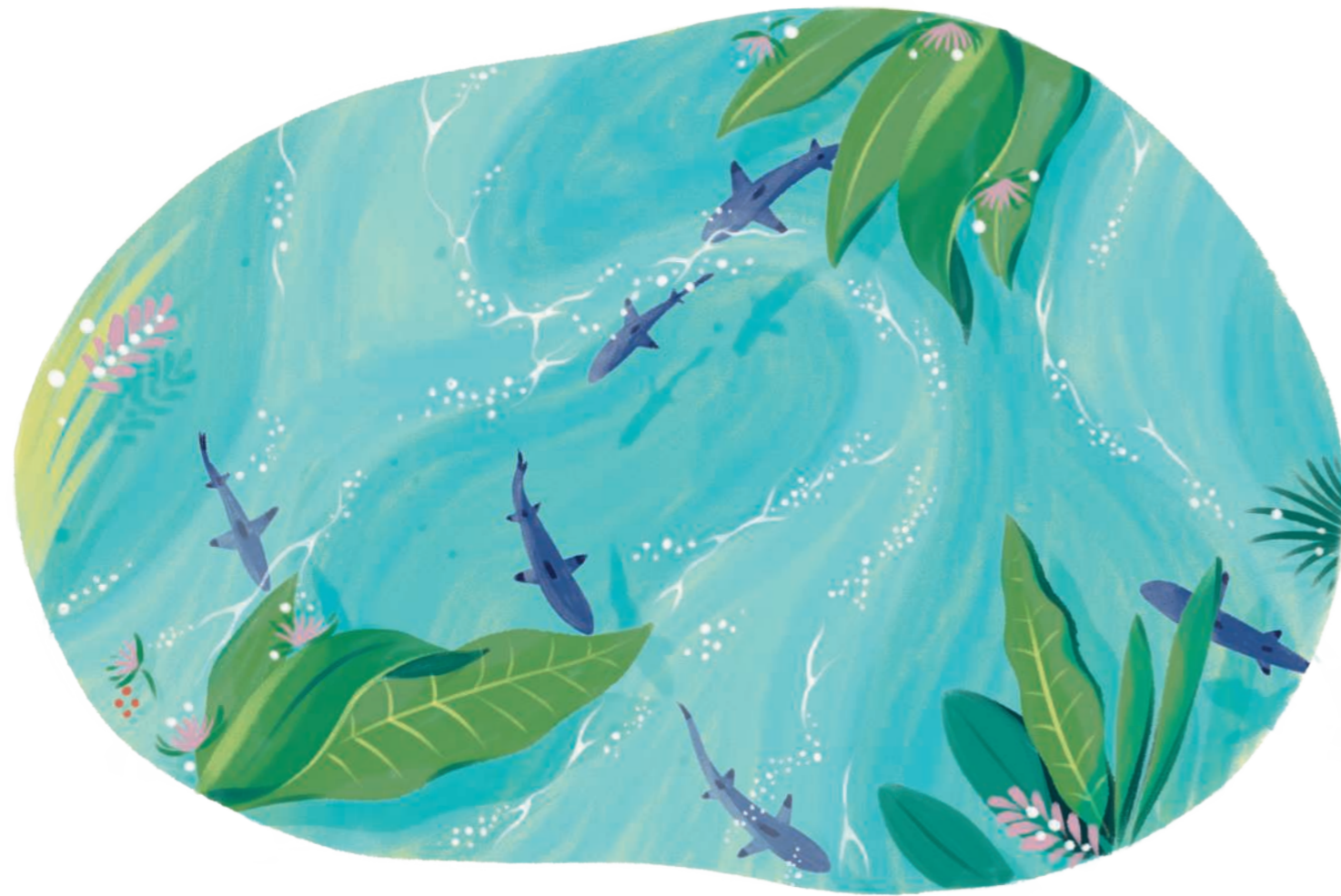

Lagoon lab

With its ash-grey volcanic tips, lush green foliage and white sandy beaches, Mo'orea is a smaller, more tranquil neighbour of Tahiti, where Papeete, the vibrant capital of the archipelago, sits. A flourishing coral reef encircles the island, protecting it from the restless waves of the Pacific Ocean. Closer to shore, the shallow waters of the lagoon are turquoise blue and crystal clear, providing an expansive window into the mysteries of thriving undersea ecosystems. Here can be seen schools of tiny fish, sea kraits, rays and many other creatures swaying in and out of the colourful corals and sea plants that are scattered across the soft, sandy seabed.

During the blacktip reef shark's breeding season, which runs from mid-September to February, female sharks in the last few months of their pregnancy enter the glassy, shallow waters around Mo'orea to give birth before swimming back out to sea. The newborn pups swim in the opposite direction, making their way closer to the warm-water nurseries near the coast. These enclosed waters make ideal natural laboratories in which scientists can study how blacktip reef sharks react to the stresses of climate change.

As pups, these sharks are experiencing conditions that scientists predict will be widespread in the oceans by the middle of this century, says Dr Jodie Rummer, the head of the Physioshark project, and some of their physiological traits may be able to tell us what sharks will need to survive in the future. Ten nursery sites around the island – some closer to the tourist hotspots than others – were identified as sampling locations by the Physioshark team.

On this particular night in December, undeterred by the incessant rain beating down, the team members got to work on the blacktip reef shark pup in the tank of sea water. Their first job was to check if this particular

shark had been caught previously and tagged with an electronic chip. The scanner did not beep, so it was a new shark in the hands of the Physioshark team, who then swiftly set about tagging, measuring and photographing it.

'It's like a machine,' says Rummer of the speed and synchronisation of the process to tag and measure the sharks before releasing them back into the ocean as quickly as possible. 'It has perfect harmony – like a choreographed dance,' she adds. 'It is also non-lethal and minimally invasive.'

Rummer first arrived on Mo'orea in 2013 to begin what would become the Physioshark project, a collaboration between James Cook University, Australia, and CRIOBE, the international research station on the island. In the early days she worked alone, which she admits was tough. Then she recruited one PhD student after another and together they researched topics from the temperature and carbon dioxide tolerance of the shark pups to their recovery from exercise, and shark predator-prey patterns.

A core part of this work includes sampling the blacktip reef sharks' 10 nurseries around Mo'orea every fortnight during the five-month pupping season. Over the years, the scientists' sampling techniques have evolved to perfection and become the rhythmic series of steps the team so routinely carried out on the night of the rainstorm. By now, each nursery has been sampled 120 times for 360 hours each. The project currently has 3,600 hours worth of sampling data from approximately 3,000 unique shark pups, from which it has created a gigantic, one-of-a-kind database of physiology, image and DNA data of juvenile blacktip reef sharks. 'It's a pretty remarkable dataset; there's nothing like it in the entire world. I am very proud of our efforts,' says Rummer.

WORDS BY

Dimuthu Attanayake

OCEAN STORYTELLING WRITING GRANT WINNER

ILLUSTRATIONS BY

Jasmine Hortop

In the world's largest shark sanctuary, scientists are attempting to map out how blacktip reef sharks can survive climate change.

There's an air of melancholy on the island of Mo'orea in French Polynesia, a sprawling tapestry of five archipelagos in the Pacific Ocean. No stars are visible through the steady downpour and, unusually, the night is dark and chilly. The only main road winding around the island is, for the most part, empty; rain is keeping people indoors. Despite the bleakness of the night, four figures huddle under a tree next to the ocean at Pepetoi, in the north-western part of the island. They are drenched to the bone, shivering in the chilly weather, but they are clearly there for a purpose.

At regular intervals, one of the four breaks away from the group and enters the shallow ocean, walking away from the shore as they search with a headlamp for something. Several times they wade back to the beach, shoulders hunched, arms wrapped tightly around their bodies, trying to keep the rain at bay.

Suddenly there's an excited shout and a flurry of activity. More people start wading through the water to a spot where the light bobs up and down. There is a scuffle beneath the waterline in what appears to be a net. Within

seconds, two pairs of hands propel a thrashing, torpedo-shaped object through the water, then place it in a portable tank on the shore. The animal is the size of a large salmon, its pale grey body writhing in and out of the water and its inky, black-tipped fins flapping. Just a few moments earlier, this juvenile blacktip reef shark had been swimming in the shallow water surrounding the islands of French Polynesia.

A keystone predator in coral reef ecosystems, the blacktip reef shark is listed as globally Vulnerable on the IUCN Red List due to overfishing and habitat degradation. In the expansive seas of French Polynesia, however, these sharks swim free.

Droplets of water splash onto the four people as they gather around the tank, carrying out their rhythmic, coordinated work. They are researchers tagging blacktip reef shark populations in Mo'orea for the Physioshark project, a decade-long study looking at how shark pups in shallow water near coasts cope with conditions that foreshadow how climate change will transform the ocean.



Climate change in a shark sanctuary



During the shark breeding season, the juveniles in these shallow areas experience three major climate change stressors: elevated temperatures, low oxygen levels and high carbon dioxide levels. In some areas close to the shore, where the water is no more than 40 centimetres (16 inches) deep, the tropical sunshine beats down during the day, heating the water and making its temperature soar. While sunlight rippling through the water makes iridescent patterns, algae and coral are photosynthesising and generating oxygen. At night, as the algae and coral respire, this process reverses. 'We get a low-oxygen, high-carbon dioxide situation at night,' explains Rummer – and these conditions are expected to become more widespread across the ocean as the climate crisis continues. Elsewhere in the world, overfishing and bycatch are the most common challenges to sharks. But in these remote Pacific islands the situation is different. The vast expanse of sea that makes up the exclusive economic zone of French Polynesia with its 121 islands and atolls – a sweeping 4.5 million square kilometres (1.7 million square miles) or so – has been a sanctuary for sharks since 2006. In fact, it is the largest shark sanctuary in the world. And as a bonus, the reefs surrounding the island of Mo'orea shield it from tidal influence, which allows Rummer and her team to study how shark physiology changes with climate stress – and without having to take into account the fact that their subjects may be legally caught and killed by fishers.

But the dotted lines drawn around countries and bodies of water do not hold back ocean warming, ocean acidification and atmospheric emissions. As the latest facets of the climate crisis unfold, the PhysioShark scientists are focusing on how blacktip reef sharks react to new stresses such as increasingly frequent oceanic heatwaves. As ocean temperatures rise, there may be disproportionate effects on the coral reefs and in the shark nurseries, Rummer says – and gradual and sustained ocean warming can be lethal to corals, as can shorter, sharper heat spikes. So far, the field research shows that in these shallow, crystal-clear nurseries, the temperature can easily increase to 35 or even 36 °C (95 or 97 °F). As Rummer knows only too well, this is very warm. 'There could be a 10 °C (50 °F) change in a day,' she says. Despite this, the data indicate that there has not been a significant drop in the number of newborn blacktip reef sharks over the past decade. This, taken together with the physiological data the team has been collecting, gave them the critical breakthrough they were looking for: it is clear that these shark pups can tolerate and live in these extreme



climate conditions. 'It's actually pretty amazing,' marvels Rummer. She and her team speculate that the conditions in these nursery areas provide the juvenile sharks with an advantage during the early stages of their life, be it protection from predators or access to food and shelter. 'But we are still trying to understand that,' she admits. She thinks that such an advantage may improve the juveniles' fitness, enabling them to tolerate the more extreme conditions brought about by climate change. 'But we don't know whether, as adults, they would still be able to tolerate the new conditions,' she adds.

The blacktip reef shark grows more slowly than similar-sized species of bony fish such as tuna, and it takes at least eight years to reach sexual maturity. And despite a relatively long gestation period of 10 months, current trends indicate that only one out of four pups usually survive to adulthood. 'Generations are too long to allow these sharks to keep pace with the rate at which we are changing their habitats,' Rummer says.

The Physioshark project

Over the years, the project has developed into an interdisciplinary, collaborative research programme that involves researchers at different stages of their careers. Rummer says she aims to not only inspire but also inform, and to share what they learn with the community, and hopefully policy-makers too.

Each scientist joining the team tries to answer questions about blacktip sharks, tapping into the data and published research, building on it and coming up with something new – sometimes even more questions. For instance, Shamil Debaere, a PhD student from Belgium, carried out the first quantitative study on how umbilical scars of shark pups could be used to estimate their age. His findings provide a crucial upgrade from the existing qualitative techniques, which used classifications such as 'open', 'partly healed' and 'recently closed'. Debaere's method will contribute to more accurate estimates of how climate change and other stresses influence the life cycle of the blacktip reef shark.

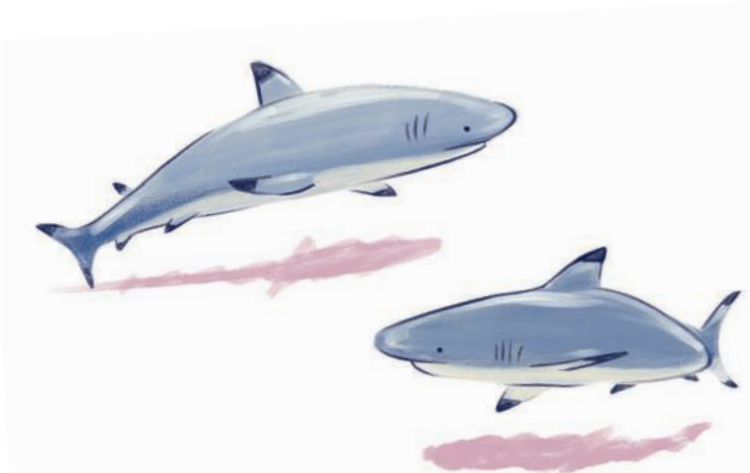

In 2023, Rummer's research focused on monitoring the behaviour of shark mothers, in collaboration with colleagues in the USA. She wanted to know 'what makes a good mama and how that translates into strong, healthy babies', she explains, adding that pregnant sharks are as vulnerable as newborns or shark pups. Scientists from Physioshark are currently tracking the routes taken by female sharks when they are about to give birth to identify exactly where in the aquamarine waters they deliver the pups and the conditions they experience during this process. The tags on these female sharks also indicate where they go to recover after giving birth, providing a sliver of understanding in the vast expanse of undiscovered facts about the sharks' lives. DNA samples are extracted too and will eventually match mothers and pups, adding another layer to the knowledge of these species.

So far, the existing research indicates that female sharks do not care for their newborns the way humans do. Instead, they give birth in specific areas of the shark nurseries where ambient temperatures are suitable for them and food is in plentiful supply. 'So if this environment is getting too warm or if habitats are lost because of coral bleaching, then that's going to compromise the pups eventually,' Rummer notes.

It has been close to two decades since French Polynesia was proclaimed a shark sanctuary and the Physioshark team is looking at what extra layers of protection could strengthen shark conservation in this region. Its existing database shows where the nurseries are and the time of the year the shark pups are in the nurseries. 'If we can add an extra spatial and temporal level to conservation efforts – to say, let's just try to keep any extra stress out of these areas during this period – then that will give the pups a little more of an advantage and maybe a little more of a fighting chance at surviving and making it out beyond the reef to become adults,' says Rummer.

It was another day on the island of Mo'orea. The Physioshark team was sampling again, this time at Tiki, a picturesque little beach with white sand and cornflower-blue water. Team members pull the fishing net across the water. Then they wait until the first shark pup shows up. In the distance the sun is setting, a golden fireball making a perfect reflection on the sea's calm surface.

Tuiterai Salmon is a native of the island and one of the Physioshark scientists leading the sampling efforts in Rummer's absence. He sits on the beach, enjoying a sandwich before the flurry of activities begins once more. Others in the team play with a stray dog.

Suddenly the net starts shaking. But this time the shark swims away before the team reaches it. Salmon wades out to the net and removes other fish that have been caught, releasing them back to the ocean. And so the wait continues, as the sun sets and dusk settles. Finally, a shark is caught and a familiar wave of excitement spreads through the team as they spring into action, repeating the same rhythmic movements as they started recording the first set of data for the day.





Fishermen help to beach a large wooden boat at sunset near the coast of Apam, Ghana. Each boat is hand carved over months by local fishermen and carpenters. Boats are customised with American flags, football team logos, Bible verses or mantras.

COASTAL CONNECTIONS

PHOTOGRAPHS BY
Gabriella Angotti-Jones

OCEAN STORYTELLING PHOTOGRAPHY GRANT WINNER



Kids play among fishing nets in Apam. Nets are handmade by boat crew members and can take weeks or even months to complete. They have been learning to make nets from as young as six years old.



WORDS BY

Lauren De Vos

Gabriella Angotti Jones went on assignment to explore shark and ray fisheries, and the scientists keeping tabs on them, in Ghana and Cameroon. Her lens captures the human experience: in her frame, our shared silliness is as important as our sorrows.

'There are so many stories to cover, and it feels like we're on the cusp of something revolutionary. Young people want to know what's going on; they're on social media platforms re-looking at the world. I think that, in the end, we can all just relate to the human experience.'

Gabriella Angotti-Jones realised early that while her passion is for the ocean, and her identity is shaped by a life lived in love with the coast, her true skill lies in connecting unguardedly with people, observing, interpreting and understanding what binds us. Raised by an ocean-loving mother in a southern Californian beach town, this self-described 'beach rat' was quick to perceive that there were challenges to solve in our seas. But it was only later, as a photojournalist, that her unique abilities could take shape. Gabriella can divine what makes a story unique and what is simultaneously a universal theme that we can all connect to.

What is most obvious is her unabashed capacity for finding joy. It weaves through her work, this connection between Californian surfers and Cameroonian fisherfolk. Joy is both resilience and resistance, and essential to our experience as human beings'

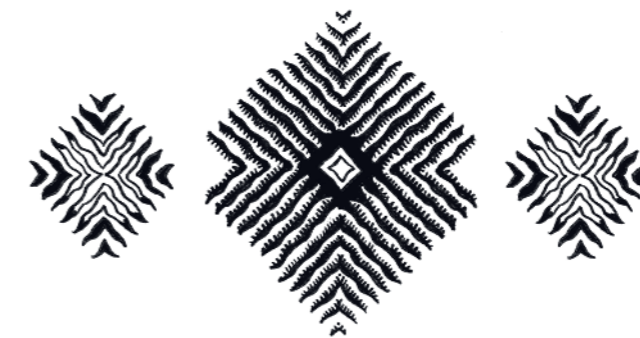



'We can't talk about conserving animals without looping in the people who are directly connected to these animals,' Gabriella begins, her voice full of passion. 'You can't talk about the conservation of sharks and rays without talking about fishers. Full stop. There's a trickle-down approach that has often been used in conservation that ends up scapegoating people who are over-regulated, fined or restricted in the lifestyles they've been following for centuries.'

The waters of West Africa are a treasure trove of biodiversity; the Gulf of Guinea accounts for some 90 species of sharks and rays. And thanks to work spearheaded by Dr Aristide Takoukam Kamla in Cameroon, we know that some 40 shark and ray species are caught in the country's waters, 34 of which are threatened with extinction. In fact, sharks and rays represent 97% of the reported bycatch in Cameroon's fisheries. They are sold and consumed locally. In Ghana, Dr Issah Seidu has shown that up to 80% of fishing income in some coastal communities comes from sharks and rays. In fact, the country is one of the region's major shark- and ray-fishing nations and shark meat is a cheap source of protein for most coastal fishing communities.

But the region is also awash with foreign vessels: industrial trawlers and shrimp fisheries that compete with and encroach on artisanal fishers. There is a conservation issue here, and it is connected to the security of coastal communities and their culture, their livelihoods and the dignity of their future.

'So that was my project: tap into the fishers and ask them what's going on,' says Gabriella. 'Show how they live. Show how they're using the animals and show how it's important. I'm innately a beach person; a surfer and a water person. Having that connection with the fishers opened conversations about how experience is wealth and that their experiences on the water form part of their spirituality - something I know. I could go up and chat to them about how the water was that day - was it rough? - and then simply listen.'



Top: Blue sharks are filleted on the shore at Dixcove in Ghana while fishmongers observe, dictating cuts and preferences.

Below: Fishmongers sell the daily catch at the largest fish market in Douala, Cameroon.





Above: In Ghana, fishermen head out to fish and find joy in the sea.
Below: In Cameroon, fishers celebrate by racing during the Street Whale Festival, and young orphans often work for boat owners in exchange for food and a place to stay.



Two Ghanaian women pose for a portrait at one of Accra's marine protected areas. Ghana is trying to expand its network of these areas as the country's economy grows. Ify Ifunanya (left) was a musician filming a music video.



"West Africa is a paradox: it's pluralistic, it's straightforward and it's not – it's so many things all at once. There are many different influences colliding here: there are locals and foreigners; there are people coming for resources and there are people trying to give the resources to locals; there is the ever-present legacy of colonialism. And then there are surfers! There are fishers! There are beach-goers!"

Gabriella pauses to take a breath before she exhales. 'The only way I could process it was to use different formats because that placed me in different perspectives.' Another West African voice, Nigeria's writer and poet Chimamanda Ngozi Adichie, famously frames the pulse that Gabriella's instinctively put her finger on as 'the danger of a single story'.

'So when I picked up the digital camera, I was in my best *National Geographic* conservation research mode,' she chuckles with delight. 'And I would take technical, newsy images. But when I picked up my film camera, I felt like I was in my friend-making mode – I was there just having a good time. And when I picked up my Polaroid camera, I was there absorbing everything with my friends.'

Gabriella's photographic journey through Cameroon and Ghana is a scattered marketplace of moments and memories; your eye is drawn to the cloth you came for but distracted by the glitter of other sellers' wares. Each image vies for your attention – enticing, encouraging, exuberantly declaring its value in this magpie's miscellany. But you'd be mistaken to think there's no clear through-thread, that this was simply the inevitable echo of the clamouring, colourful chaos of wax-print fabrics and fish sellers and bikini-clad beach babes and brightly painted wooden boats. 'Pay attention,' the images grin, bargaining for your time. 'Look deeply at what is here. These are people. Theirs is a story that cannot be contained in these frames and these pages.'

'There seemed to be so much extraction happening,' she continues, 'and it doesn't really leave room for the locals' stories: their enjoyment, their stake in their resources, their connection to their coast.' And in its colonial past, in parachute conservation and curation of media reporting, there seems little room left for the lived stories of local people.





Chantal Ndokon-Youh (right) plays in the water with a friend in her village of Londji, Cameroon.

Gabriella's images veer from research in action to the exuberance of children playing in an ocean of fishing nets. They show fire in the gestures of speakers in community meetings and the zen of surfers on the Gulf's generous waves. West Africa is not just one thing. There is the holy morning light as fishers push their boat into the dawn and there is the desecration of a manta ray left dying in the shallows; there is the sass of a seaside Venus in a crocheted bikini and there is the familiarity of a coast-side football game.

'I want us all to pay attention and observe what's really going on here. Just because we don't understand something doesn't mean we have to look the other way – or reframe it in our own understanding.' And Gabriella's natural inclination is to pay attention to where people are at ease, where their stories might be most true. In one frame, two fishers laugh, their eyes creased, shoulders hunched in a candid moment of shared comedy beneath the etched hull of their wooden boat. 'I think I know the dynamics of beach culture and where the joy happens, so I'd go there. The images of joy or levity had been missing for me - and I find that hard to believe because we're all human beings.

'I want the photos to be about the people in them and their experiences. That's it. When people look at these images, I want them to see West Africa for what it is: not the preconceived notions we all have about what is a complex place with a loaded history, context and future, I think maybe that's why I have captured so much joy.

'I don't want to see pictures of dead animals anymore!' Gabriella exclaims. 'I want to see pictures of how people fit into how these animals are dying and how it fits together.'



G H A N A I A N F I S H E R S

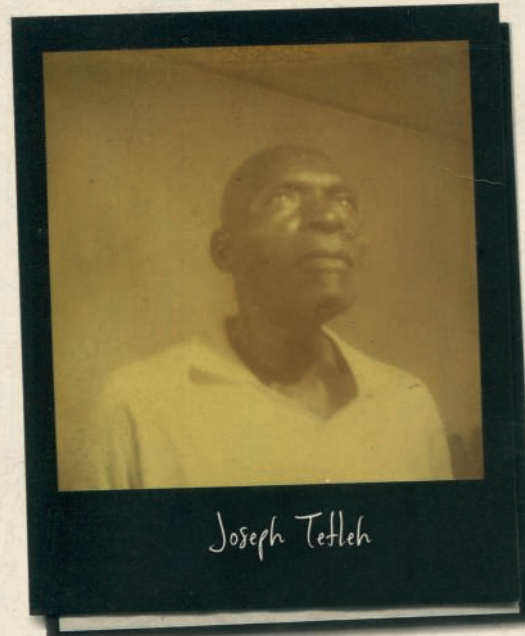
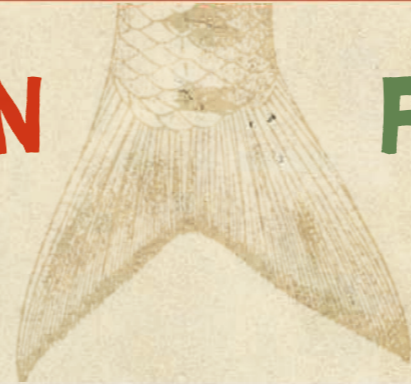

Joseph Tetleh

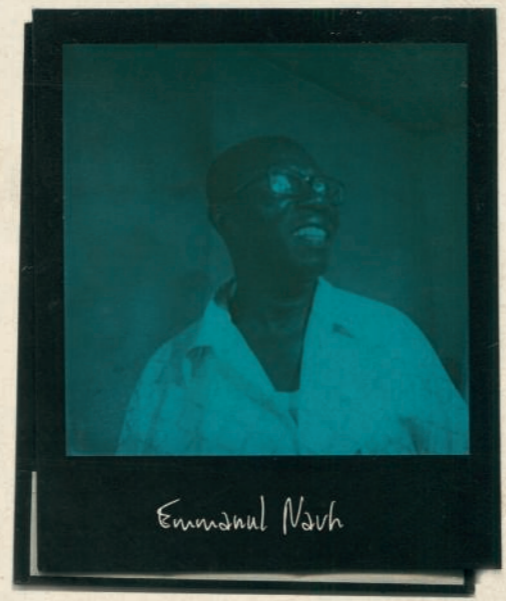

Emmanuel Navih

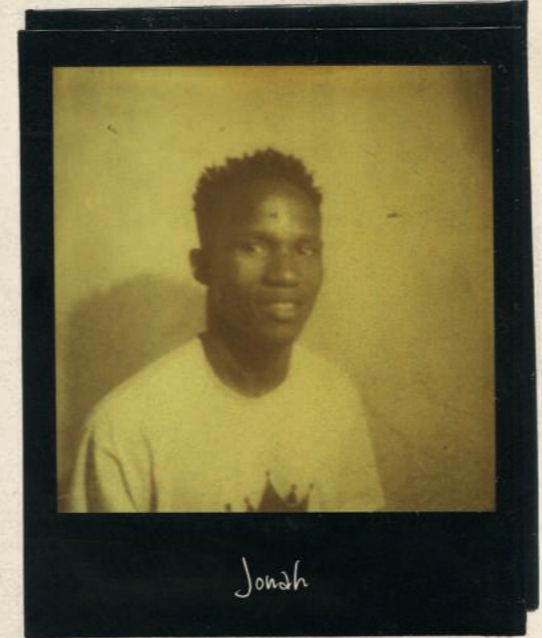

Jonah

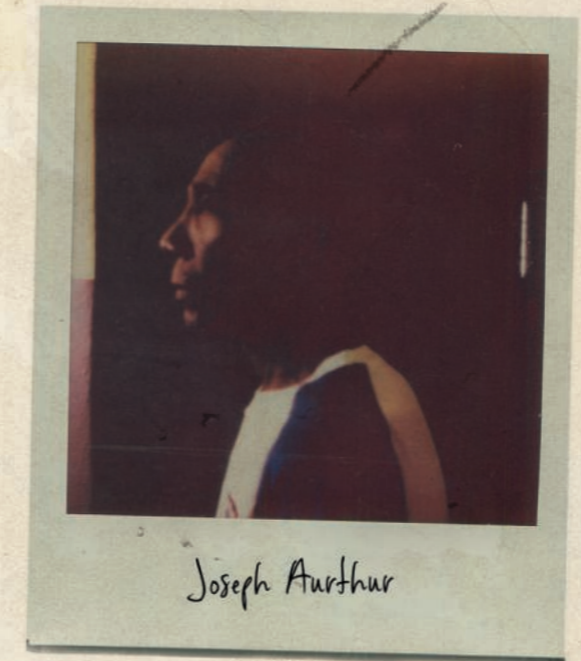

Joseph Arthur

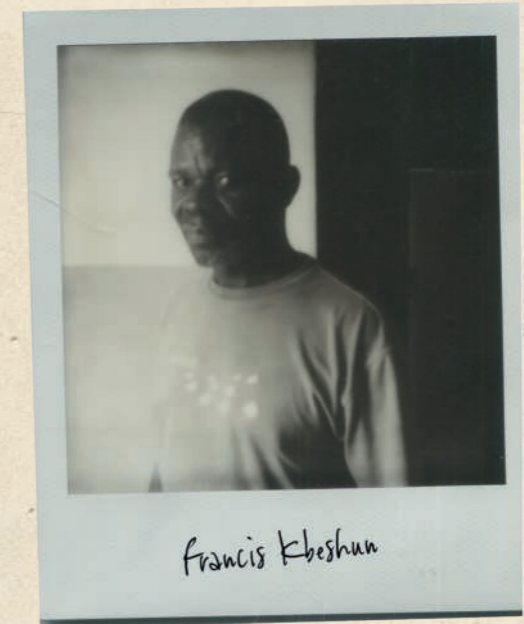

Francis Kbesahun

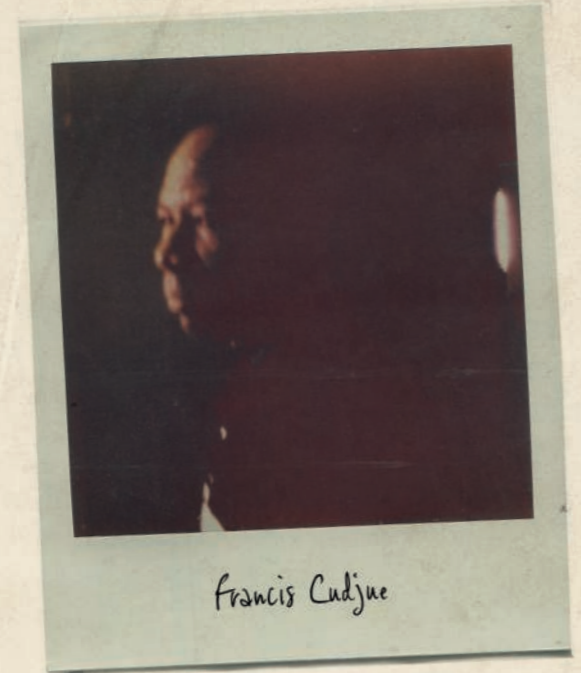

Francis Cudjue



Joseph Binney



Christian Sasa

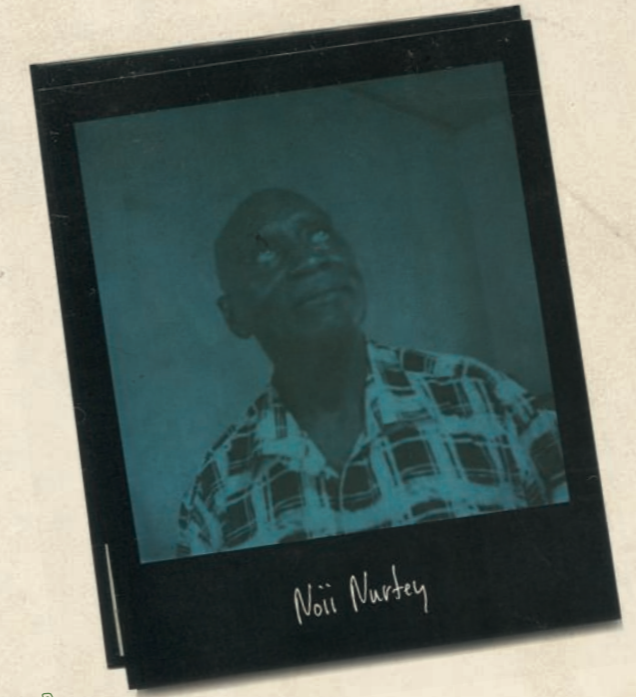

Nii Nurtay



Michael Noko



Ghanaian fishermen from Dixcove, Axim and Busua pose for portraits. Most are leaders in their communities and boat owners who collaborate with Dr Seidu, helping him to advocate for fishing laws and practices that address their concerns and will help them to survive.

Listening to music on his air pods, Isaac, a fisherman and one of Dr Seidu's assistants, searches for sharks and rays as part of a market survey in Apam.





In her Polaroid photographs, Aristide and Issah are at once her now-familiar friends – young men with interests and goals and ideals – and scientists carrying the full weight of their coastlines so early in their careers.

‘I hope I have a small part to play in showing people that these are people navigating multiple conservation issues descending at once, and they are doing it with such innovation and dedication.’

These scientists aren't just collecting data by identifying and measuring sharks on the beaches; they're actively including fishers in their process and, as work by Issah has shown, there is major overlap in the value presented by fishers' ecological knowledge and data collected through research. Aristide's organisation, the African Marine Conservation Organisation (AMCO), has created a network of 80 fishers who use an app to document their catches, including sharks and rays.

Gabriella's work captures something of the human spirit and experience, but she challenges us to honour those experiences and grasp why they are important.

'I'm so excited to see the research coming out from West Africa, because I think when it's paired with the images, it's going to make a lot of sense.' Indeed, the hard numbers paired with the emotion, context and connection that good storytelling can bring is the manifestation of that convincing argument for change she ardently believes in.



Top: Researcher Gofrane Labyneh greets a fisherman who has been helping to identify sharks, rays and sea turtles for iNaturalist in collaboration with the African Marine Conservation Organisation (AMCO) in Limbe, Cameroon.

Bottom: A local fisherman expresses the fishers' needs during the fuel crisis of March 2023 at a meeting of local fishermen, chiefs, boat owners and former fishermen during Dr Seidu's presentation in Axim.





Pierre Ndokon-Youh (left) fixes a fishing net with his son, Samuel, in Londji, Cameroon. Pierre doesn't want his kids to become fishermen and is helping them to learn English and French and to focus on school.



A member of Surf Ghana catches a left at Busua near Dixcove. Surf Ghana has been instrumental in creating an equitable surfing community, and kids are learning how to compete in contests and shape boards.

ACCIDENTAL SHARK SANCTUARY

WORDS BY

Fanni Daniella
Szakál

OCEAN STORYTELLING WRITING GRANT WINNER

ILLUSTRATIONS BY

Kelsey Lee
Manners Dickson

The Port of Ngqura has a higher abundance of fish than anywhere else along South Africa's coastline. Can it teach us a lesson about supporting nature in the face of increasing human development?

I knew there would be sharks. But I didn't expect quite this many.

Within minutes of our small rubber boat leaving the dock, the large brown shapes of several ragged-tooth sharks emerge from below us. They bob their heads above the water, gulping air and showing off their needle-like teeth. Unconcerned by our presence, several dozen more show up until we are surrounded by sharks. We are not on Palmyra Atoll or some other uninhabited shark paradise far from humanity, but in the Port of Ngqura, an industrial harbour 20 kilometres (12.5 miles) east of Gqeberha, South Africa.

On the breakwater to our left, African black oystercatchers scour the dolosse for mussels. To our right, cranes – the industrial kind – are loading hundreds of six-metre (20-foot) containers onto an enormous barge. Blurring the line between human and nature, the whistle of the wind and the cries of seagulls mix with the whirr of engines and the thud of cargo landing on the barge. The salty air and a whiff of guano from a nearby nature reserve mingle with the scent of petrol.

Vivienne Dames turns off the engine and fits two cameras to a metal frame, pointing them towards a bait box filled with crushed sardines. She hoists the whole contraption over the side of the boat and, using a long rope, lowers it slowly to the sea floor, speaking as she works. 'The raggies will drag this around like it's nothing,' she says, referring to the three-metre-long (10-foot-long) ragged-tooth sharks circling us.

Dames is a PhD student at the South African Institute for Aquatic Biodiversity whose research focuses on fish communities, specifically sharks and rays in the harbour. Based on the video footage that she collects at different locations around the port, she hopes to get a better idea of the abundance and diversity of fish in different types of habitats and to pinpoint what it is that makes artificial structures fish-friendly.

We move away, leaving the fish to discover the cameras in peace. As we head towards the shore, we are again quickly surrounded by a shiver of sharks. 'They don't look like much of an endangered species now that there are like 70 around us,' Dames shouts over the rumble of the engine.

Ragged-tooth sharks are in fact Critically Endangered according to the IUCN Red List. They are slow to grow and reach maturity and they only give birth to two pups every two years, so they are especially vulnerable to overfishing, which has caused their numbers to plummet in many countries over recent years. But seemingly oblivious to the large-scale industrial operations at the harbour, they gather here in large numbers, using the calm waters as a refuge.

And they are not the only ones. The port is home to an incredible diversity and abundance of fish. In an area of just a little over 1.5 square kilometres (0.6 square miles), there are more than 100 different recorded species, including 12 Endangered and six Critically Endangered sharks and rays. Abundance, which is often measured by the number of catches by an





angler in a unit of time, is 2-3 times that of any other nearshore marine protected area in the country. In summer certain sharks, like smooth-hounds, gather in massive shivers where 'you can't even put your feet in the water without stepping on a shark', according to Dames.

Around the world where major urban centres meet the coast, over half the shoreline is covered by artificial structures. While South Africa still has long stretches of its coastline undeveloped, with the country's recent commitment to 'unlock the ocean economy' this is likely to change. By better understanding how this unique environment became a sanctuary for fish, Dames hopes that her research will provide guidelines for building on coastlines that support diverse marine ecosystems, prioritising the interest of humans as well as nature.

'We're not going to stop building alongside the ocean,' she says, 'so we need to understand how these creatures adapt to artificial structures and make them their own.'

I look through the fence to the sandy beach beside the harbour. Big, white-capped waves rush onto a shore that stretches as far as the eye can see. Dames points out a rip tide, a strong current of water pulling everything with it offshore. The port was built in 2006 over this high-energy surf zone by dredging the mouth of the small Coega River. Today this calm, sheltered bay, about 20 metres (65 feet) deep, bears no resemblance to the harsh environment that was here before.

Matt Dicken, now the head of research at the KwaZulu-Natal Sharks Board, started monitoring fish abundance and diversity when work on the port began. A small team of volunteer anglers dart-tagged fish and, when the port became operational in 2009, they followed how the fish communities changed. More than 12,000 data points have been gathered to date, making this one of the largest - and longest-running - datasets in a port environment.

At first they found species usually associated with sandy beaches in the area. Then, as invertebrate life began to colonise the rock-like structures of the port, they started catching more reef-associated species. A diverse marine ecosystem seemed to have made a home here, with several

endangered species using the port as a nursery. Some species that normally occur in warmer, tropical areas, like manta rays and spinner sharks, also began to show up.

'When man-made structures are created, most people will start thinking that development is going to ruin it,' says Dicken. 'But as far as the fish life goes, this port has done the exact opposite. It's created an incredibly unique, sheltered environment that provides a sanctuary for fish, resulting in the most diverse species composition and highest abundance of fish anywhere in South Africa, if not Africa.'

Remarkably, the harbour seems to be especially popular with sharks and rays, which account for about a third of the species recorded.

As the second most threatened vertebrate group globally, sharks and rays are in peril, with one-third of their species threatened with extinction. The long time they take to reach maturity - a whopping 150 years for the record-holding Greenland sharks - and their long gestation mean they are not able to reproduce fast enough to keep up with fishing pressure. The practice of shark finning alone is estimated to kill about 100 million sharks each year.

South Africa, a global hotspot for sharks and rays, currently protects only 5% of its waters, and even there certain types of fishing or shark control in the form of shark nets and drumlines are permitted. Lack of enforcement is also an issue; people often refer to protected areas as 'paper parks', meaning that in practice there is no one there to uphold the law.

In the port, however, all fishing except for the fish monitoring programme is strictly forbidden. As we enter the premises, we are stopped at the security gate and a guard scans our papers, checks our permits and looks through the car for anything suspicious. Passing the security cameras towering over the road on our way in reminds us that our every move is supervised. Essentially, while they stay within the safety of the breakwaters, all the sharks need to worry about is being eaten by a bigger shark.

Later that week, we sit down with Dames at the home office she shares with an assortment of rescued creatures to watch the videos that she took in the harbour. Moving a wayward kitten out of the way, I bring my focus to the screen. About a hundred fish are swimming around in the mint-green waters, raiding the bait box in a frenzy. 'That's a ridiculous number of fish,' says Dames as she plops a mealworm into the mouth of a swallow chick - the latest rescue. I can hear the crackle of the reef and the strange murmurs of dusky kob, a very vocal and very endangered resident of the port. Then a massive raggie swims into the picture and bites down on the sardine box, pulling the whole camera scaffold with it, as our view is blotted out for a few seconds by a snowstorm of sand and debris.

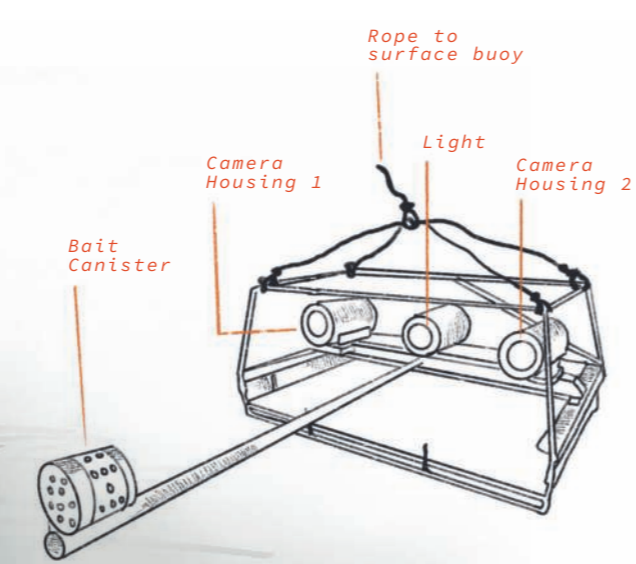
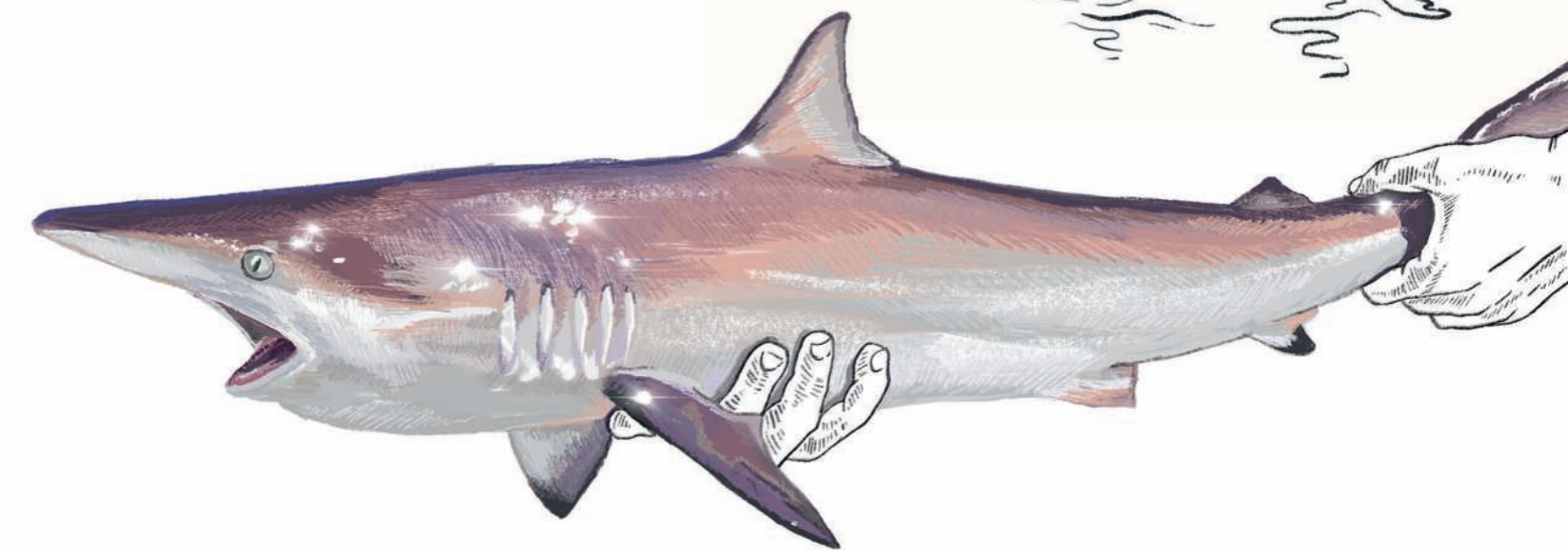



We see species that have never been caught by the angling team, like chimaeras, the rare cousins of sharks and rays, and shysharks, sting-rays and big bronze whaler sharks. Looking at footage taken at different points around the harbour, we are transported to a new micro-ecosystem in each one: a shiver of sharks circling the bait along the quay walls, rays flapping around in the turbid waters at the sandy beach, bustling reefs of bryozoans and gorgonians along the dolosse. According to Dames, the diversity of habitats is one of the key reasons behind the unexpected ecological success of the port.

'Oh my god.' Dames jolts up in her seat. 'A new species!' She points to the silvery fish with a yellowish line on its side swimming in and out of visibility. She identifies it as an almaco jack. I ask her if she knows *all* the fish by heart. 'Pretty much,' she replies. Visibly buzzing with excitement, she rewinds the footage to take another look.

Dames lives and breathes fish. She used to tag along with her father on fishing trips as a child and has fished her way up to the top of South Africa's recreational angling scene, scoring some sponsorship deals in the process. Hooking fish is perhaps a strange passion for someone with a primary goal of protecting the oceans, but Dames seems to have forged a path where her two identities – angler and scientist – are working to each other's benefit.

'Scientists mostly stick to themselves and their conferences, and they think that's the end of it. But unless [the research] has some meaning for the people who actually handle the fish every single day and are using them to feed their families, what difference are you going to make?' she questions.

'You need to walk in their shoes. I found that the only way I can make a difference is to fish among them.'

In an ideal world, the oceans would be teeming with sharks, maintaining the delicate balance of marine ecosystems. The coast would be untouched and there would be no need for sanctuaries, refuges or protected areas. Clearly, this is not the case. Humans have significantly altered two-thirds of our oceans and the number of artificial marine structures are projected to increase by 50–70% this decade. Coastal development often leads to the destruction of crucial habitats like coral reefs, sea-grass meadows and mangrove forests, with ripple effects that sometimes extend hundreds of kilometres through changes in water quality, noise, substrates, movement of animals or food webs. The artificial structures like flat seawalls, pilings or marinas that are put in place are also associated with alien species, paving the path for biological invasions.



So I was astonished to find that a commercial port has one of the highest diversities of fish on South Africa's coastline. But it is not the only example of marine life thriving in a man-made environment. Offshore oil rigs, the monstrous metal structures sticking out of the sea that have become synonymous with environmental destruction, support an incredible diversity and abundance of marine creatures. So abundant are the sea creatures around them that there is a movement towards leaving these structures in place after the rigs themselves are decommissioned.

Sydney Harbour in Australia is another example, with almost 700 fish species recorded to date – almost as many as you would find in the entire Mediterranean Sea. It has some of the most diverse fish assemblages and the largest sizes of fish compared to other estuaries in New South Wales, including protected areas. The main reason for the harbour's ecological success seems to be its diversity of habitats. As a drowned river valley, Sydney Harbour is made up of inlets, mangroves, salt marshes and rocky reefs, providing plenty of options for fish to pick and choose what they like.

The harbour was the birthplace of Living Seawalls, which are ecologically designed concrete panels that try to emulate natural structures. Each panel has different designs on the surface, sporting pockets, holes, slates or structures resembling a honeycomb. Shaped like unruly hexagons, they fit together like a mosaic and offer habitat and refuge to a variety of creatures. The panels that now cover some of the seawalls in the harbour provide homes for about three times more species than would be found on a flat seawall.

'I don't think we're going to eliminate coastal infrastructure,' says Katherine Dafforn, who is a co-lead in the project. 'So I think we need to think about how we build them smarter, so that we can have beneficial outcomes for diversity and beneficial outcomes for humans as well.'

I am standing on the little sandy beach nestled at the back of the harbour, looking out at the expanse of grey water. The wind is chopping up the normally smooth surface of the sea, rolling waves towards the shore. It is too windy to go out on the boat, so instead I'm helping the angling team to catch sharks and rays. Helping is perhaps a bit too generous a term, as I have never held a fishing rod in my life before. Now I'm holding one that

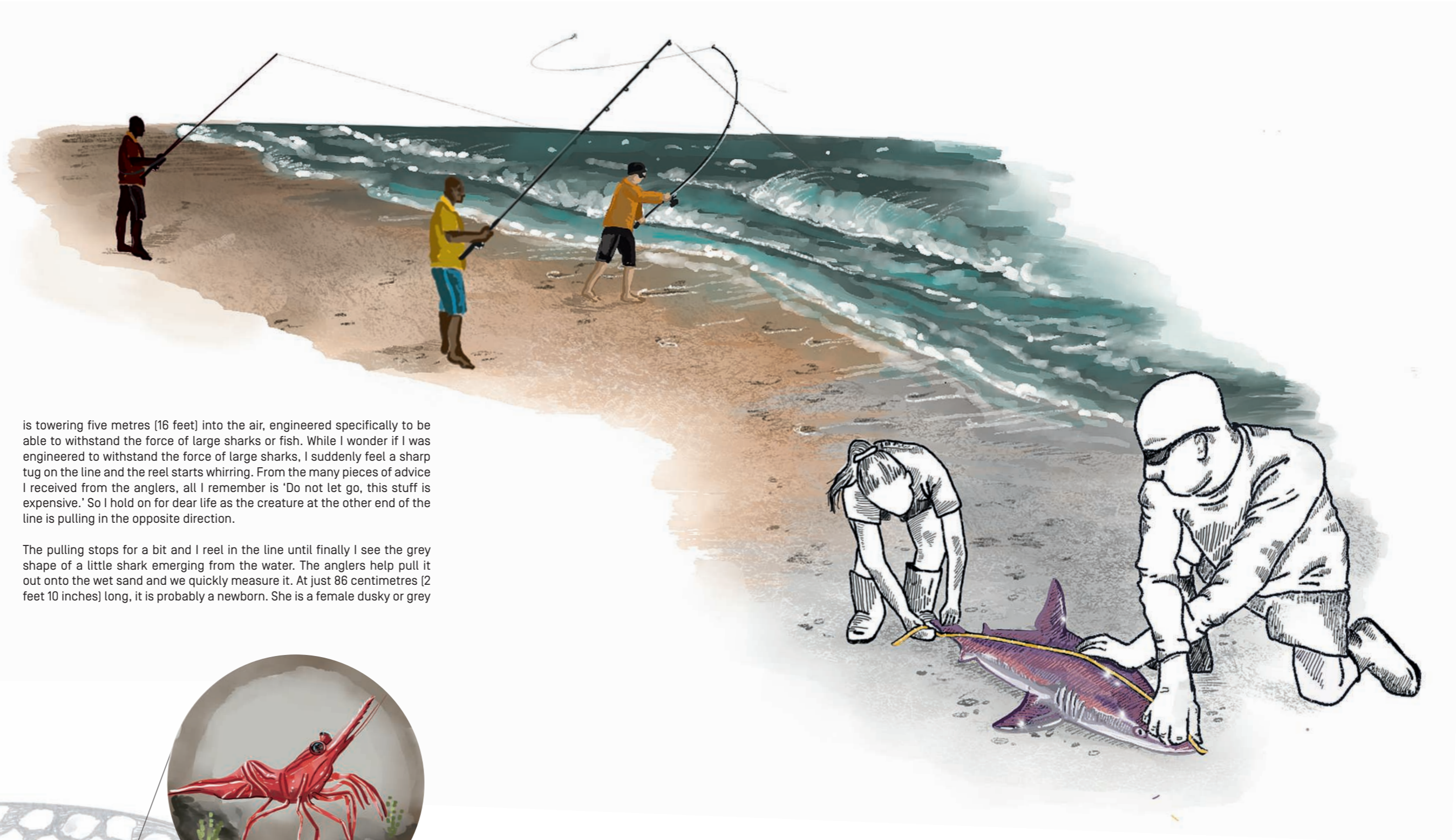

is towering five metres [16 feet] into the air, engineered specifically to be able to withstand the force of large sharks or fish. While I wonder if I was engineered to withstand the force of large sharks, I suddenly feel a sharp tug on the line and the reel starts whirring. From the many pieces of advice I received from the anglers, all I remember is 'Do not let go, this stuff is expensive.' So I hold on for dear life as the creature at the other end of the line is pulling in the opposite direction.

The pulling stops for a bit and I reel in the line until finally I see the grey shape of a little shark emerging from the water. The anglers help pull it out onto the wet sand and we quickly measure it. At just 86 centimetres [2 feet 10 inches] long, it is probably a newborn. She is a female dusky or grey



shark, an Endangered species that has established a nursery here and is now the most commonly caught shark, with an estimated 550 individuals in the port at any one time.

One of the taggers carefully removes the hook from the shark's mouth so as not to cause any damage, while another disinfects the tagging needle and attaches a small yellow dart tag next to the dorsal fin. The whole choreography of fine-tuned movements takes about 30 seconds, minimising stress to the shark as much as possible.

The taggers release her into the water and I look at her as she swims away with a firm slap of the tail. I think about her future. Perhaps she will become the dinner for a bigger shark or end up in the nets of fishermen waiting outside the harbour. Perhaps she will grow big and strong and will be caught

again, granting us important scientific data. As a migratory shark, she may travel thousands of kilometres northwards along South Africa's coast. Perhaps she will support her species by coming back to the port one day to pup.

In any case, right now she is the poster child for paving the way to an uncertain future where humans and nature can co-exist in relative harmony – the literal grey area between pristine nature and destroyed ecosystems.

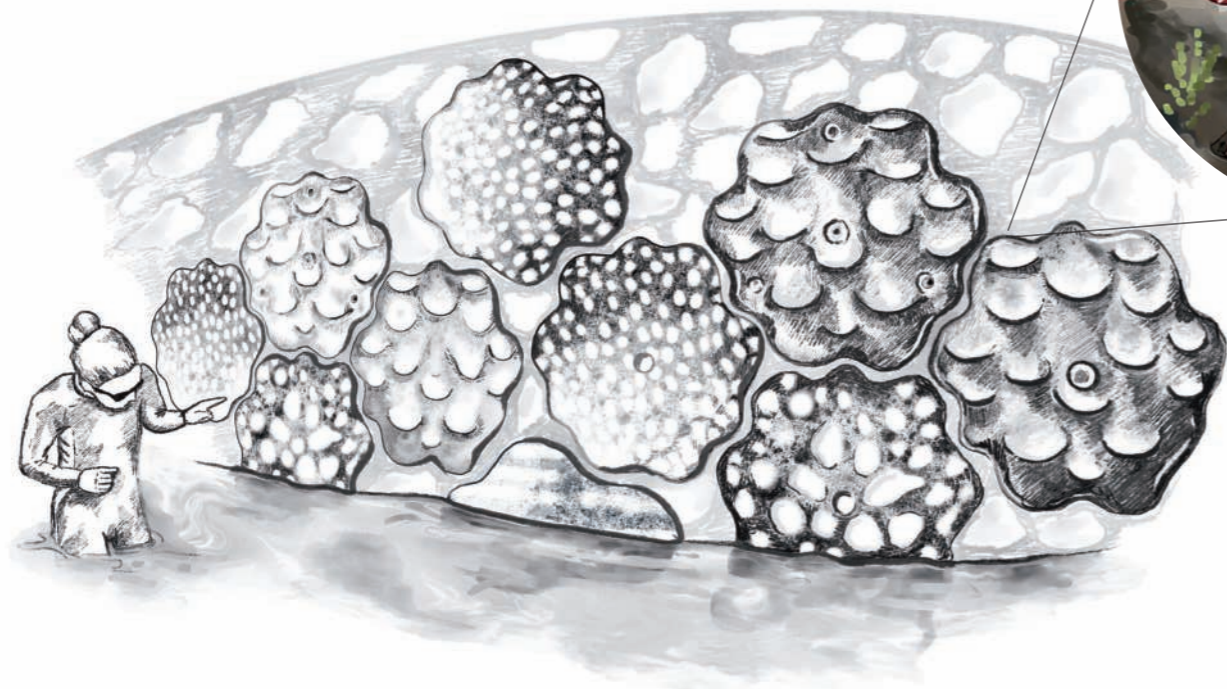



INTERTIDAL IMPACT

PHOTOGRAPHS BY

Sarang Naik

OCEAN STORYTELLING PHOTOGRAPHY GRANT WINNER

WORDS BY

Lauren De Vos

The intertidal zone is a challenging place where wildlife is hemmed in by human impacts from land and sea. Sarang Naik nudges us to look locally, to pay attention to where wildlife exists and to find community to effect conservation change.

It's unusual to be a person who notices; who, to borrow from Mary Oliver, pays attention and is astonished by the natural world. And on Mumbai's coast, where the cityscape teeters towards the Arabian Sea, the natural world risks being drowned out in our consciousness as life clamours across India's most populous city. But Sarang Naik is a photographer who sees what gets overlooked on his home city's shores.

'I have lived in Mumbai my whole life,' he begins, 'but had never thought of the city's beaches as rich in wildlife.' The zoology-graduate-turned-photographer has come to know the coastal belt in all its colour, complexity and caprices. Sarang has spent the better part of a decade learning the language of wilderness on his doorstep, and in one of the most unlikely places on earth he has learnt something powerful: 'Wildlife is everywhere!' His photojournalism underscores his hope for this planet. 'Don't just think it's in sanctuaries or national parks. It's everywhere; you just need to look.'

Sarang has trained his lens on the intertidal zone, the strip of shore between the tides. Plants and animals here are some of the toughest on our planet, adapted to a world that is part submarine, part terrestrial. Citizens of the low shore risk pounding waves and competition for real estate and resources; those higher up are beaten by blazing sun and can lose up to 70% of their body water through evaporation (we humans expire if we lose 15% of ours). It's a natural laboratory to excite the most eager scientist. And a world where the ocean's whimsy and wonder are readily exposed for happy beachcombers.

But there is something more essential to this place: it's our first step from land back into the sea. Coastlines have grown our brains and shaped us as modern human beings. The sea retreats at every low tide to bare its bounty, only to reclaim the shore in a celestial rhythm that we have communed with for hundreds of thousands of years. And while not everyone has a boat, can dive or owns a rod and reel to cast, almost everyone can access the span of shore that opens between the land and the sea. Its very egalitarianism makes it a place under pressure for the longest time and from both land- and sea-based threats. The intertidal zone is harvested, developed, dredged and polluted. With our changing climate, it risks rising sea levels and fluctuating ocean chemistry. But what worries Sarang most is that it is overlooked and underestimated. 'Mumbai's coastline is synonymous with pollution. The first thing that comes to mind is a coast overcrowded with people, with filth spewing into the sea,' he says soberly.

'What people don't realise is just how much wildlife persists here.'

Previous Image: Flamingos congregate in a tidal lake next to apartments in Navi, Mumbai. Thousands of lesser and greater flamingos visit the city annually.

Right: Anemone-like zoanthids glow under an ultra-violet light. These are colonial animals, linked by a sheet-like tissue that carpets the shore.

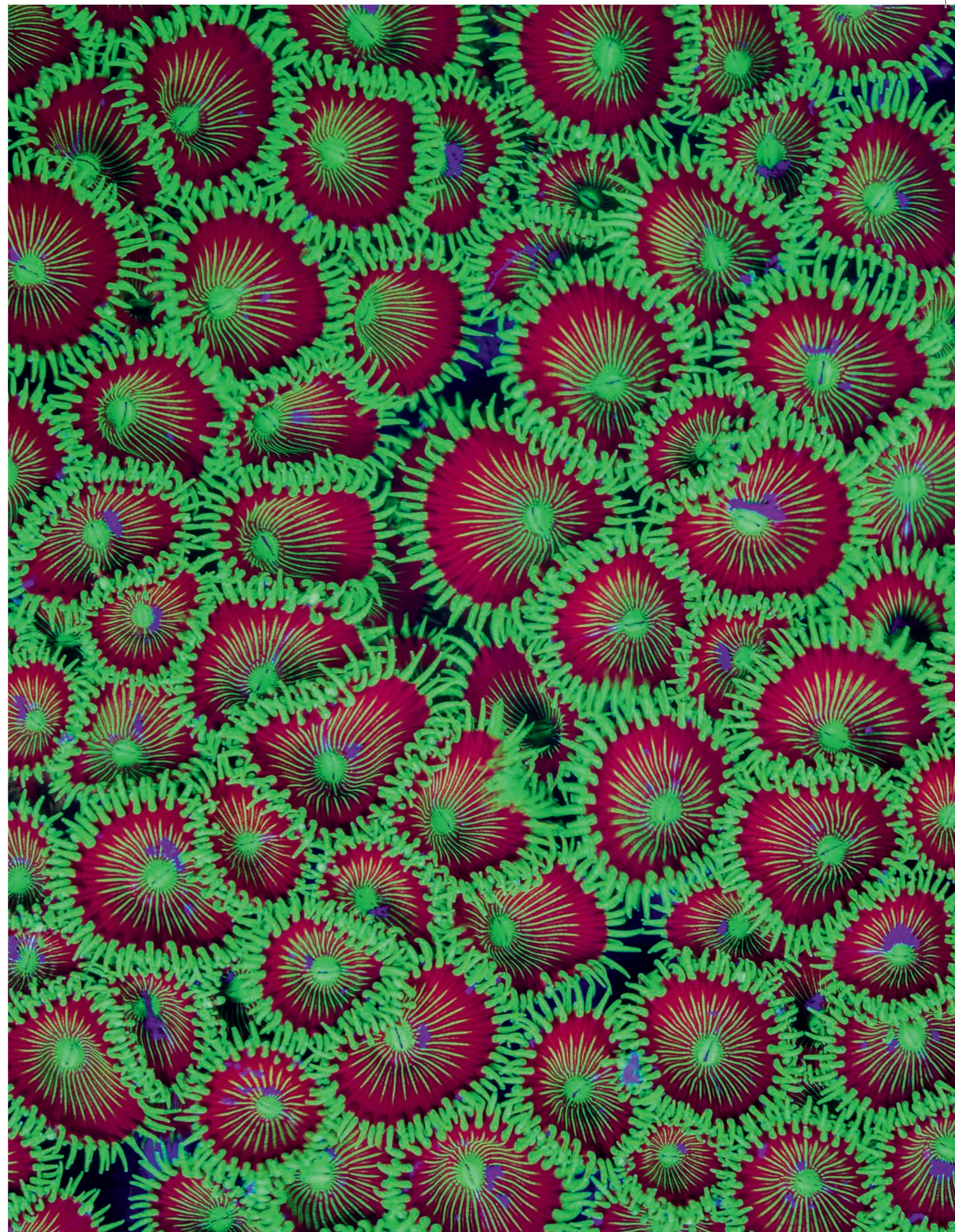

More than 500 marine species have been recorded on the Greater Mumbai coastline, where a city hums along the length of rocky, sandy and mixed beaches. On the diverse rocky shores, crescent-banded grunter swim in tidal pools that house common octopus, moray eels and beaked sea snakes. The rocks are crusted with barnacles, oysters and limpets; there are sea stars and sea snails, seaweeds and algae, shrimps and sea slugs. On sandy beaches, burrowing worms lead subterranean lives, while windowpane oysters and textile clams are scattered among button shells and blood cockles.

'Marine Life of Mumbai was started in 2017 by marine biologists, photographers and concerned citizens who had realised that the city's shores also harboured wildlife that needed to be documented,' explains Sarang. 'That was the catalyst to my career in marine wildlife photography. Exploring with this group opened my eyes to Mumbai's incredible blue biodiversity and I decided I had to start documenting it in a way that opens other people's eyes too.'

In Sarang's Mumbai, flamingos crowd the coast in their statuesque hordes. Their colourful abundance is only made more extraordinary set against the arboretum of apartments that obliterates the sky. A tiny Bombay dorid sends a lurid warning to other tidal-pool dwellers that is as neon as the lights that electrify the skyline. And the sleepless secrets of millions of Mumbai's residents are reflected in the nocturnal glow of a pool of violet zoanthids; there are just as many nocturnal dramas afoot on these reefscape.

Wide-angled and macro shots wrest wildlife from obscurity to how they appear in Sarang's mind: fascinating and worthy of our respect. 'My photographs intentionally make these animals and plants the focus, offset by the cityscape behind. Over the years, I avoided the stereotypical narrative of toxic decay. These animals live here; we must pay attention.'

Right: Fishermen have spread out a beach seine net, locally called a *rapan* or *rampon* net, to dry after a morning's fishing in Caranzalem, Goa.



But people live here too; all 23-odd million of them in the world's fourth most populous city. With nearly 73,000 people crammed into just under every 200 square kilometres (73 square miles) of Mumbai, the pressure on marine resources is enormous. 'It's fascinating to observe that the more polluted the shore, the more densely populated with wildlife it has sometimes become. Those animals that could adapt have done so. There are certain coral species, for instance, that we find only in waters with high sewage content,' says Sarang. And the people who harvest in the intertidal zone endure, despite the obvious health risks. 'They say that they have been doing it for generations,' he explains.

'This is another issue that no one is looking at. All along the city's coast people collect bivalves, intertidal animals that are known to accumulate heavy metals. Harvesters have told me that when they boil the bivalves at home, the entire place smells of oil.'

Left: A mass beaching of Portuguese men-of-war happens around August every year in Mumbai and is always accompanied by large quantities of oil, tar balls and other trash.

Sarang's work now incorporates more of the pollution. The intertidal zone is a meeting place – of sea and land, of high and low tide. Hemmed in as houses and harvesters approach from the shore and as pollution and fishing encroach from the sea, it's where the toughest survive. But Sarang still nudges us towards nature as the lead character: a beaked sea snake strewn among the tide's discards; the natural meeting the unnatural as Portuguese men o' war, which typically beach en masse along the coast in monsoon season, wash ashore tangled in tar balls and plastic. As much as we engulf, consume and appropriate, nature persists.

'In Mumbai, I know where to go and what to look for. So I find that seeking life in the intertidal zone here, unlikely though it would seem to most, is relatively easier than what I would have to learn to do elsewhere.'

The crush of the city that Sarang left behind for his first international assignment – and first overseas trip – has given way to milkwood trees clustering above beaches where cattle occasionally wander and traditional rondavels dot the hillsides. In the lush hills between the Mtata and Mtamvuna rivers in South Africa's Eastern Cape province lies Mdumbi, a village on the Transkei coast that is home to the amaMpondo people. Echoes of the issues that plague his home shores surfaced at nearby Coffee Bay ('there was some tourism-related pollution') and further afield in the cosmopolitan city of Cape Town ('there were headlines about sewage outfalls and pervasive plastic pollution') but, he says,



A honeycomb moray eel behind Mahalaxmi Temple in March 2020, shortly before the Covid-19 lockdown. That was the last time this shore was untouched. Authorities began reclaiming the shore and by the end of November the upper and middle intertidal area had been completely reclaimed.



Zoanthids glowing under UV light at night in Mumbai. They capture tiny prey but, like coral, get food from symbiotic zooxanthellae algae in their tissues.



'When you're coming from Mumbai, everything looks pristine to me - and Mdumbi really looked unspoiled.'

The ability to see the natural world despite the intensity of Mumbai is perhaps only possible because Sarang has a reverence that disciplines how he frames what he finds. And patience and reverence are what are needed to document the Wild Coast - the informal name for the coastline that extends from the Great Kei River to the Umtamvuna River. It is aptly named: shipwrecks litter the sea floor, leaving ghostly traces in place names and in some of the people who now inhabit the coast. The sea heaves during storms, its powerful currents plaguing marine researchers who try to record the subtidal life offshore. Any familiarity with the life on its rocky shores requires years of study - or generations of communion by the people who have lived on this coast for hundreds of years.

Limpets, barnacles and mussels all cling to these wave-battered rocks. People harvest shellfish, bait, seaweed and shells from the coast, with distinct patterns in who collects and when harvesting happens. Here, Sarang stumbled on links to this more rural, coastal community he'd not previously understood. He recounts the relationship between the fishers of Mdumbi and its rocky coast: 'The women and young children go to the shore at low tide, harvesting limpets by plucking them from the rocks with a tool. They string a long collection of limpets onto the end of a line and then the men go out late at night to catch crayfish.'

Sarang was kept at arm's length (not just by spring tides, safety concerns and a dearth of natural history information) because the fishers forbid lights on the shore - no disturbance permitted, the crayfish are skittish. And, knowing that there are many and varied, and ancient, ways that people commune with the coast, he complied. It's what he does best: witness, study, understand - all to relate more intimately with the intertidal. There are familiar echoes here of the years he has spent memorising the patterns of tides and seasons; the lore, the routines of people who witness wildlife on their ancestral coasts are all a lesson in paying attention. Sarang's sights aren't set solely on the intertidal any more.

'I honestly feel quite overwhelmed when I look at the state of things, sometimes. But then I think that there are many of us realising that we must do what we can. And we must build community. We can do something locally, together. Whenever I join a research group or any other active group of citizens, it gives me so much hope - and that is powerful. You focus on what you can do.'

It's not surprising that a photographer whose eye was drawn to the intertidal, where animals and plants live in community, seeks the same for himself. If the tides have taught Sarang anything, it's that conservation will always be this push-and-pull, but his approach reminds us that our hope - and our futures - will depend on how we build communities ourselves.

Fossils and shell middens from around Waterfall Bluff on South Africa's Mpondoland coast suggest a human presence on this shore 35,000 to 10,000 years ago.





Bait collectors searching for bloodworms at low tide in Mdumbi.



Shaping Marine Conservation in Cameroon

WORDS BY

Wenzel Pinto

OCEAN STORYTELLING WRITING GRANT WINNER

ILLUSTRATIONS BY

Lizzy Stewart

Imagine pursuing a Master's dissertation about an animal you had never heard of, and one you almost never saw while you were working on that dissertation. As incredible as this sounds, that is exactly how Aristide Takoukam Kamla began his conservation journey in 2010. Today he is one of Cameroon's – and Africa's – foremost marine biologists and is changing the way young people in his country and around the continent are working towards preserving the natural world.

Early in February 2024 I found myself on a plane to Cameroon. I had never travelled internationally before and hadn't expected the West African country to be my first destination. Nevertheless, I was thrilled that it was. Being a marine biologist myself, I was curious to learn about how Aristide had crafted his journey and how the conservation space he worked in differed from Lakshadweep, the archipelago in India where I work. Neither Lakshadweep nor Littoral Cameroon are cosmopolitan, buzzing, resource-rich areas of the world. The challenges of governmental control and censorship, getting access to funding and balancing conservation agendas with the needs of local communities all felt like common ground.

I was on this journey because I had received a grant from the Save Our Seas Foundation, which also funds Aristide's work in Cameroon. The grant allowed me to spend time with him and profile his work and the conservation initiative that he founded: AMCO, or the African Marine Conservation Organisation.

Cameroon is a small country that hugs the west coast of Africa. Often called 'Africa in miniature', it contains a multitude of the continent's ecosystem types, from savanna and dry scrub to lush equatorial rainforest, from montane forest and grassland to mangrove forest, and from riverine deltas and sandy beaches to unexplored shallow water reefs. Cameroon's people are just as diverse, being made up of 240 tribes, each with its own unique language.

Aristide almost did not become a marine biologist because, although he has an affinity for wildlife, he did not see it as a career. 'I was always fascinated by marine life, but I saw conservation as something that was done in the western world. I had no idea I could do this as a job,' he explained. He recounted the time he first found out about manatees, back when he was studying for his Master's degree. His professor had assigned the class a literature review, but on that day Aristide had not been present. As a result, he was left

with the last of the 14 topics to choose from: Aquatic Megafauna of Cameroon. 'What is megafauna?', he remembers thinking. To find out more, he searched through books and learned about a large aquatic mammal found in Cameroon's rivers. 'Until then, I never knew that a creature like the manatee was found in Cameroon. So I wrote up my review and decided to do my dissertation on the African manatee.'

Manatees are marine mammals, as are dolphins and whales. They live in seas and estuaries. They have enormous, bulky grey bodies that can weigh up to half a ton, and a large paddle-like tail to propel themselves through the water. Aptly nicknamed 'sea cows', they are gentle giants, swimming slowly through rivers and bays, grazing on plants along the water's edge and only occasionally snacking on clams and fish. Of the three manatee species found in the world, the one least known and studied is the African manatee. It has the widest distribution range of the three species, spreading down the western side of Africa from the Senegal River to Angola and spanning 21 countries. Despite its expansive range, and being so large, African manatees are exceptionally elusive, as Aristide learned at first hand.

During the six-month study for his Master's, Aristide didn't see a single manatee. 'I was disappointed, almost out of the money my mother had given me, and I was ready to give up. That is when I met a fisherman in the small village of Dizangue, near the Sanaga River. He told me about bubble trails and signs of feeding, and that early morning is the best time to spot them. The next day, he took me out on a paddleboat in the middle of Lake Ossa and sure enough, I saw my first manatee! I cried real tears because I had been so close to giving up, but now I'd found them. That is what sparked my interest.'

In the decade that followed, Aristide learned of the myriad threats that the African manatee faces: poaching for meat, entanglement in fishing nets, dams that restrict its movements, and more. He completed his PhD from the University of Florida under the tutelage of Dr Lucy Keith Diagne and soon went from never knowing about the existence of manatees to being Cameroon's leading manatee expert.



In honour of manatees

A week after landing in Cameroon, I stood at the unveiling ceremony of the Street Manatee Festival in Dizangue, which is organised by AMCO. The festival was akin to a conference: a series of planned talks, workshops and activities built around the central topic of the African manatee, its habitat and its conservation.

Holding a conference is all about getting people's voices heard, but to bring together a wide-ranging group of individuals so that they can communicate with one another is no easy feat. The Street Manatee Festival had the most diverse set of presenters and attendees of any such event that I have been to. There were researchers from Cameroon, as well as invited speakers from the USA, France, Great Britain and Algeria. Representatives from several major wildlife conservation NGOs working in Cameroon attended. Chiefs from all the villages surrounding Lake Ossa were present. And there were people who had been displaced by dams, and government officers who worked for the departments of forests, electricity and dams. A concerted effort was made to include every group of people who had any stake in the manatee, and the voices of each group were heard at the meeting.

The only way the festival could have been any more inclusive was if a manatee had given the keynote. Well, we had the next best thing. Aristide stood alongside village chiefs and the forest conservator as the artwork was revealed...

The curtain was pulled aside and out popped a large, grey blob – an artist's rendition of an African manatee. The artwork did not paint a flattering image of the creature, but that was no fault of the artist. With its large, bulbous body and dull grey skin, the manatee can hardly be described as a good-looking animal!

Nor is it even easy to see. The streams and lakes where it occurs are thick with sediment, rendering the large mammal nearly invisible. The only manatee sighting one can hope for is the tip of a nose popping up to breathe or, on rare occasions, its snout above water, pulling riparian vegetation into its mouth. Yet this was the animal that had not only sparked Aristide's interest, but captured the imagination of so many. Manatees have often been touted as the inspiration for the myth of the mermaid; more locally, in West Africa they are also thought to have been the origin of a water deity, the Mami Wata. In several parts, manatees are even considered to be akin to humans, and killing them is therefore a sin. It was not hard to see why more than 150 invitees had gathered for a festival to celebrate manatees and the ecosystem they inhabit.

The Street Manatee Festival ran for three days and the energy was electric. Since Cameroon is a bilingual country, there were talks in both national languages, French and English. Understanding the presentations in French was difficult for me, but I did hear some fantastic speakers in English. Dr Lucy Keith Diagne, Aristide's former PhD adviser and now director of the African Aquatic Conservation Fund (AACF), spoke about the African manatee, its ecology and interactions between it and humans, as well as the biggest threats to its fragmented populations.

The sessions focused not only on manatees however. James Ackworth from the Central African Forest Initiative spoke about the relative importance of the forests of Central Africa in the global context. And there was a workshop about the SIREN app, led by Cedrick Fogwan from AMCO. SIREN is a simple smartphone app that helps fishermen and other citizens track fish and marine megafauna through photographs and GPS coordinates. The data from it can then be used to tackle fundamental questions about monitoring the diversity of ecosystems, understanding the geographical range of species or estimating population sizes of marine life – all questions that are now of utmost importance to Cameroon.

Conservation challenges in Cameroon

Cameroon's vast resources in wood, oil and gas, and arable land were exploited by not one, not two, but three colonising powers: first the Germans, from 1884 to 1916, and then the country was divided between the French and the British. It has been independent since 1960, but the internal conflicts of a largely rural population and a high dependence on the rich natural resources have resulted in complex conservation issues. For the manatees this means facing a variety of threats, even though they have been afforded the highest level of protection in Cameroon's wildlife legislation. In addition to being hunted for meat and getting entangled in fishing nets, manatees have had to contend with the construction of dams – the primary means of generating electricity – and the fragmentation and destruction of their habitat. This mix of conservation challenges requires nuanced solutions and it seems that AMCO is tackling the issues on many levels.

On my last day in Dizangue, I went on a boat trip on Lake Ossa, in the hope of spotting one of these animals that I had now heard so much about. Living up to their slippery reputation, manatees were nowhere to be seen. What we saw instead were abundant signs of the disruption of the lake's ecosystem. Tattered and discarded fishing nets lay strewn along canals or washed up ashore. The edge of the lake painted an unsettling paradox of organised rows of oil palms and the tangled mess of dense tropical evergreen vegetation. Occasionally, as we moved around a bend, we would come across what had been a large tract of forest, now illegally razed to the ground to make way for more plantations. Conservation is at its most difficult when a species' survival crosses paths with people just trying to eke out a living.



Even more prominent, though, was salvinia, a small-leaved floating fern from South America that has been taking over the surface of the lake for nearly a decade, and whose spread AMCO has been working hard to curb. In places it was forming such dense mats that tall grasses and even small trees began growing over it, making the lake's surface resemble a floating savanna! Annick, AMCO's site coordinator at Dizangue, has worked to repurpose salvinia into charcoal, giving people incentives to remove this invasive weed by hand. On another front, Aristide and his colleague Cyndi have been working hard to cultivate and introduce the salvinia weevil, an insect that feeds only on this weed, in the hope of reducing the area colonised by the ferns. In the four years since they began, this biocontrol agent has reduced the salvinia cover in Lake Ossa by more than half!



AMCO: past, present and future

I asked Aristide one evening what his vision for AMCO's future was. 'Harmony between humans and nature,' was his reply. 'AMCO can retire peacefully if this is achieved.' This highlights one of the core values AMCO holds dear: working together with local people. 'The only way we can work towards conserving nature is by heeding what the community has to say as well.'

This epiphany struck Aristide one day when a fisherman saw him travelling with acoustic equipment and complained, 'You carry all this expensive equipment to survey manatees, but you do nothing for the people in the community. And you tell us not to hunt them. It seems like you care more about the manatees' lives than ours.' The fisherman's words resonated strongly with Aristide and since then the human dimension of conservation has become a central part of AMCO's work. Creating alternative sources of livelihood and actively engaging with the needs of the people, as well as enforcing environmental laws, have ensured the complete cessation of manatee hunting in Dizangue – a feat that is hard to overstate.

But AMCO's work is not just localised within Cameroon. As we prepared the stage for the Street Manatee festival, I met Morgane, a Frenchwoman who has been working with the organisation for the past five years, and is currently tackling the problem of illegal, unreported and unregulated (IUU) fishing in Cameroon.

'When it comes to fishing, the flag of Cameroon is known around the world as a flag of convenience,' says Morgane, referring to countries that register fishing vessels not based on nationality. 'Often the owners of boats are not Cameroonian, but they obtain licences from Cameroon.' These vessels frequently fail to follow internationally accepted fishing regulation, which has resulted in Cameroon receiving a red card from the European Union; the bloc will no longer import its fishery products. Morgane is now leading a project to help the government curb IUU fishing by helping to draft new legislation and creating better measures to track violations.

Meanwhile, Ghofrane, who leads AMCO's shark and ray programme, is bringing together researchers and governments from countries across the Gulf of Guinea to draft a management plan for shark and ray populations in the region. 'We started the Gulf of Guinea network to create a strategy for managing shark and ray populations,' he explains. The initial discussions in 2023 were so successful that the network is now expanding to cover a large part of West Africa.

Aristide's efforts go beyond his everyday work. As well as spearheading marine conservation in Cameroon, AMCO is ushering in the next generation of conservationists. Many of the current members of the organisation began their career as Aristide's students, working on diverse topics in the marine space under his tutelage. Clinton and Daniel are pursuing their own PhDs under his wing, while Annick, Thierry, Cyndi and Ghofrane all completed part of their dissertations with AMCO before they themselves became part of the organisation. Ceidou, a young hydrologist from Cameroon, has started his own NGO called Aquatic Environmental Management, or AQUAEMAN. When asked, he had only praise for Aristide and AMCO. 'AMCO is like the head of a snake ... paving the way for other young researchers in Cameroon [to follow].'

A few months after my trip, in May 2024, Aristide received a prestigious Whitley Award, commonly known as a Green Oscar, for his work on conserving manatee habitat in Lake Ossa. Thinking back to how this started, what strikes me is not just the work he has done, but the people he has inspired and worked with. In our very first online conversation Aristide said, 'The story need not be about me. AMCO is much more than me.' And indeed it is.



On Mexico's Holbox Island, fisherman Miguel Humberto Zapata Jimenez wades into the sea to gather bait fish for a day of corvina fishing.

PHOTOGRAPHS BY

Acacia Johnson

OCEAN STORYTELLING WRITING GRANT WINNER

THE WORLD CHANGES, AND WE DON'T REMEMBER



Isla Aguada fisherman Yamil Pantil Lopez (black T-shirt), with his brother Angel Andres, pulls in a Caribbean whiptail stingray in Términos Lagoon.



WORDS BY

Lauren de Vos

After the Second World War, Mexico pushed to populate its coastline and build some of the world's biggest fisheries. But the science to monitor this development was slower to follow. Ilse Martínez-Candelas and Nadia Rubio are two shark scientists who have recognised the invaluable information stored in the stories of the old fishers who migrated to the coast and whose tales of giant sawfish, enormous rays and shark nurseries reveal glimpses of an ocean already gone.

Photographer Acacia Johnson went on assignment to capture the essence of a coast and its people, who are adapting to a fast-changing world. She found a story that asks us to honour the past so as to re-imagine the future.

'If you can find young fishers here on the coast, they will tell you – the sharks are huge!' Ilse Martínez-Candelas spreads her arms and her fingers splay to encompass the bulk described to her by Mexico's shark and ray fishers. 'They will tell you that they weigh up to 60 kilograms [132 pounds]!' If you didn't know better, it would make for an impressive fishing boast. 'But then you visit the old fishers and they will tell you the sharks were up to three metres [nine feet] long and weighed 120 kilograms [265 pounds]!' Ilse recounts how disgruntled the shark-fishing elders feel now.

This gradual dulling of our collective memory of the environment, this slow acclimatisation to a degraded state that is accepted as normal, is so commonly encountered that fisheries scientist Daniel Pauly termed it the 'shifting baseline syndrome' in a 1995 essay. Our perception of the ocean changes; we quickly overlook what a place once was and live with our imaginations limited by this dilution of abundance.

'Young fishers aren't as connected to the ocean any more,' explains Ilse. 'They've been born into this degraded system, so they think that's simply the way it is.' Working with the fishers of Términos Lagoon in Campeche on the Yucatán Peninsula, where the history of fishing dates back to the Mayans, she has been interviewing coastal fishers to fill in the gaps in an otherwise data-poor shark fishery. 'My dream was to be a marine biologist who dived coral reefs – I never dreamed about growing up to talk to people!' she laughs. 'Then, when I was monitoring coral reefs, I visited a coastal community once a week. And the fishers would tell me their stories...'

Realising that these fishers' experiences could offer the understanding that was missing, Ilse started baking batches of cookies to offer during interviews to glean more insights. 'They were terrible cookies! I'm an awful baker!' she giggles. 'But before I knew it, I had started enjoying my time with the fishers more than my time monitoring coral reefs. I was

learning about sharks, but also gaining these fascinating insights into people's lives. It made me realise that our science could be better. People are not only information sources; these fishers are, to me, another kind of scientist.'

With some 217 species of sharks and rays, Mexico is home to 18% of all species in the world. At the same time, it's an important shark- and ray-fishing nation, with an average yearly landing of shark- and ray catches that places it fourth globally after Indonesia, Spain and India. Mexicans also consume shark and ray meat, to the extent that they even import it. But, like many fishing nations the world over, many fisheries in Mexico are considered data-poor. Key to addressing overfishing is adequate information and government scientific monitoring started only after many species were already in decline. 'There was not a lot of shark science; official government monitoring started in the 1970s,' explains Ilse. 'Of course there were the archaeologists: shark fishing has been in the culture of Campeche for millennia. But between Mayan archaeological records and the start of scientific monitoring in the 1970s lies a huge gap in our knowledge.'

When the reference point is set in an already degraded system, the scientists' perception of what constitutes 'healthy' has already shifted – they are led by the shifting baseline syndrome just as the young shark fishers are. So Ilse began investigating how to integrate local ecological knowledge into shark and ray fisheries management. At various stages after the Second World War, the Mexican government had promoted the development of the fishing sector, and the 'March to the Sea' populated the Mexican coast. 'The government actively supported people to take up fishing from about the 1950s onwards. Many of the fishers who are here in Campeche today migrated from inland,' says Ilse. 'Among the experienced shark fishers in Campeche, the average age was at least 70 years.'

Top: Fish and sharks have been loaded onto a motorcycle to be taken to market.

Bottom: Birds flock to collect fish guts on the beach in Holbox, Mexico. This beach, once a sawfish nursery frequented by fishermen, is now dominated by beach clubs, hotels and restaurants.





Left: Leydi Calderón Hidalgo, daughter of shark and ray fisherman Don Calderón, serves a traditional ray dish with her mother, Trinidad Hidalgo Sanchez, during a family dinner in Isla Aguada.



Right: Don Calderón outside his house in Isla Aguada. An active shark and ray fisherman for more than 70 years, he is a local legend for the rays he has caught in Términos Lagoon.

From left to right, fishermen Meco Andres Manuel Hernandez Ovando, Guadalupe Cruz Salejo and Zenon Hernandez Ovando pose for portraits in Ciudad del Carmen.



The data Ilse has collected are changing the way we perceive the state of Campeche's coast and the status of its sharks. 'For instance,' she explains, 'the official records in fisheries monitoring account for nine lemon sharks. But when we started this project, after a single year of working with fishers we increased that to more than 50 records. I think that this way of doing science, where we partner as equals with fishers, is the way forward – and may even get better results.'

Lemon sharks were common along the Campeche coast 40 years ago. The fishers knew where the females would go to bear their pups. But there are now only two communities in Campeche that have seen lemon sharks in the past decade; the rest stopped seeing them in the late 2000s. 'The knowledge of lemon sharks is fading,' adds Ilse, soberly.

'The younger fishers do not even recognise the species. This ecological knowledge that shark fishers developed over decades is being lost.'

The love for the ocean, even in its state of flux and degradation, is a pull still felt by the oldest fishers. 'Take Don Calderón for example,' Ilse grins. 'His kids sold his fishing boat because he was so determined to go to sea – even though he was in his eighties – that he used to escape from his house to take his boat out all on his own!' Despite their passionate identity and history, fishers are increasingly struggling to make ends meet. 'Being a fisher before the 1990s meant that you could buy a car and a house,' says Ilse. 'But now fishers don't want their kids to become fishers; they want

them to go to college.' She mulls over the idea of alternative livelihoods. 'I love Términos. But compared to other regions, there are few of the alternatives that have allowed those places to transition to ecotourism. The poor water visibility means that snorkelling and scuba diving are not viable.'

More than 600 kilometres (370 miles) away, in the extreme north-east of the Yucatán Peninsula, lies Chiquilá in the state of Quintana Roo on the Gulf of Mexico. Here, landlocked farmers also moved seaward to settle and fish the coast. Dr Nadia Rubio has been gathering local ecological knowledge from the fishers here and on Holbox, a barrier island off the northern coast of Quintana Roo. Holbox is influenced by currents from the Gulf of Mexico and the Caribbean Sea and receives rich upwelling from the north-eastern shelf of the Yucatán Peninsula. This upwelling – the cycling of

plankton from the depths to the surface – sustains large aggregations of whale sharks, which has helped the fishers of Holbox transition to ecotourism. In many respects, it's the idealised conservation success story.

But the relationship between people and the environment in a changing world is always complex. 'The value of fisheries changes,' explains Nadia. 'So while many of the oldest fishers had fished for sharks and rays, the fishery had evolved as value dwindled and they began to fish for lobsters and groupers too, adapting as resources declined and market values fluctuated.' Fishing is still a part of life on Holbox Island, but like Campeche and Términos Lagoon, it is becoming harder. Fishers can travel up to 70 kilometres (43 miles) a day off the coast to seek catches. So tourism, where it can be done successfully, is an attractive alternative.



During the Fiesta de la Santa Cruz in Isla Aguada, a raft of fishing boats ferries an icon of the Virgin Mary and Jesus, Lord of the Fishermen, into the waters of Términos Lagoon.

Men cast nets for small fish in Isla Aguada, a town of about 6,000 people on the coast of Términos Lagoon.



In her work with the fisher elders of Holbox, Nadia has identified more than 100 important fishing areas that were once considered highly productive. One such area is Cabo Catoche. This 'Eden', say the oldest fishers, was filled with groupers, turtles, lobsters, sharks and rays. Today, Cabo Catoche forms part of the Yum Balam Natural Protected Area and tourists flock here to snorkel among sea turtles and sea grass. Their boat operators and snorkel guides are local fishermen. Many fishers have formed tourism cooperatives, electing to become tour operators as a more sustainable alternative to fishing.

And today at least 5,000 tourists are ferried from Chiquilá to Holbox Island daily at the height of the summer holiday season. For an island that until recently counted only 1,400 permanent inhabitants, the sudden success of tourism is a double-edged sword. Water, electricity, waste disposal and sanitation are embattled services as the island's infrastructure takes enormous strain, and over the busy summer months water and electricity shortages occur. Space is valuable and contested, and plastic pollution pockmarks Holbox's loveliness.

'Fishers are very aware that things have changed in the ocean,' says Nadia. 'They know that the big groupers, snappers and big sharks have been lost. They are also aware of illegal fishing and environmental degradation.' And it's this deep-seated knowing from decades of observation that Nadia and Ilse are pushing to have included in management decisions and policy overviews. They know that as the world changes, we must remember. Without the fishers' stories, we risk accepting an ocean that – as Pauly cautioned in 1995 – is set to a reference point that continually shifts towards decline.

Right: Whale shark guide Vicente Cáceres (foreground) and boat captain Carmelo Sabatini depart from Holbox Island in search of whale sharks.



In 2019, after working on Holbox for four years, Nadia moved to Cozumel. She'd pushed to have the natural history of Holbox, Chiquilá and coastal Mexico, as told to her by the fishers who knew it best, considered equal to scientific research. But the latter's findings, attained only after the coast was already in decline, were given greater credence and Nadia, disillusioned, was close to giving up science altogether. 'I worked on tourist boats and I would dive every day and see the fish and sharks that the Holbox fishers had described to me – and I would cry,' she says. 'The fishers in Holbox used to tell me about these "turkey lobsters", as they called them. Huge things that hid in the *cuevons* – small caves that used to be crammed with groupers and lobsters. I never saw them there. But in Cozumel, I'd phone these old fishers I'd met who were still in Holbox and tell them "Today I saw a lobster as big as a dog!"'

Nadia's face lights up in the retelling of this story, her hands moving apart to indicate the size of a Jack Russell terrier. It's an image so incongruous – an armoured, antennaed alien secreted in Cozumel's submarine caves – that it could only sound like another 'fisherman's tale'. But rather than writing off the stories of the fishers they've worked alongside, Ilse and Nadia have allowed their experiences to open their minds to the possibility of an ocean we've never even considered. Their work is showing us that when we embrace the knowledge of previous generations, we stretch our imaginations to include possibilities of oceans past. And perhaps that's exactly what we need to do: stretch our imaginations to build a future far more wonderful than we could have hoped.

Left: Save Our Seas Foundation researcher Ilse Martinez offers magnets to an Isla Aguada fisherman during an interview, asking him to choose his favourite elasmobranch species.



An upscale bar faces a main street in Holbox. This former fishing community has experienced a dramatic increase in tourism and development, thanks primarily to whale shark tourism.



A motor taxi passes beneath a flowering tree in Chiquilá. This peaceful town (population about 2,300) is the departure point for ferries to the popular Holbox Island.

NOTHING COMES WITHOUT ITS WORLD

Why conservation storytelling
needs a course correction

WORDS AND ILLUSTRATIONS BY

Dylan McGarry

Not so long ago I was invited to curate an exhibition for a turtle conservation project, which was an honour, but also provoked internal discomfort. The conservation of marine wildlife like sea turtles is an ecologically justifiable and deeply needed act. Yet having listened over the years to the ongoing testimonies of displaced peoples along our South African coast in my work with the One Ocean Hub, I couldn't look away from how these efforts, these acts, often come with a kind of cultural/historical amnesia.

Speaking as a 'recovering' marine scientist myself, I was not trained in the historical or philosophical evolution of the science I was taught to practise. I was instructed to prioritise 'objectivity' and somehow separate my history, my culture, my body, my spirit, my emotions from my science. Yet no matter how sophisticated our scientific instruments become, no matter how powerful the telescope or microscope may be, the light still enters a human eye, it enters a human being nested in an ecological, social, cultural and political world.

In time, I shifted my research and studies from zoology to environmental science and then to environmental education. Within this last field, I entered the world of transgressive social learning, educational sociology and visual anthropology. I began to practise multi-layered ethnography, learning from post-humanism, critical African



feminism, scholar activism and public storytelling. In 2013, with Neil Coppen and Mpume Mthombeni I founded a theatre collective called Empatheatre and for over a decade we have supported community-led research and public storytelling. One of our most recent projects, titled *Umkhosi Wenala: The Festival of Abundance*, worked with 13 young activists living around the UNESCO World Heritage Site and marine protected area of iSimangaliso Wetland Park.

This is also a part of the South African coastline where turtles migrate each year to lay their eggs. Conservation has often told its story through individual species – ‘Save the whale’, ‘Save the rhino’ – but this framing isolates creatures from the complex worlds they inhabit. Ursula Le Guin reminds us that even the lone hero was once carried and cared for, pointing to collaboration and community over individual heroism. Sea turtles, though largely solitary, live within rich ecological networks. As Donna Haraway has written, ‘Nothing comes without its world’; turtles, like all beings, exist within layered ecological, cultural and political worlds.

Turtles understand homeland; they understand birthplace and origin stories. They always return to their place where they hatched, a phenomenon known as ‘natal homing’. Yet this stretch of coastline in northern KwaZulu-Natal is haunted. This haunting – the dispossession of Tsonga and Zulu communities to make way for the marine protected area – reveals a grim history of violent settler colonialism. In making *Umkhosi Wenala* over two years, and supporting a massive collective public re-telling of history from a Zulu and Tsonga perspective, it became

painfully obvious to us that there is a systematic conflation between colonialism and conservation. This legacy of ‘fortress conservation’, which forcibly removed indigenous and local people from their ancestral lands to create protected areas or even to facilitate mining or tourism, is commonplace wherever you look along that coastline. It even transcends the apartheid policy, notably the Group Areas Act of 1950, a law in South Africa that forced people to live in racially segregated areas, often evicting communities from their homes to enforce white minority control over their land. These actions led to the erasure of rich, inseparable customary lore/laws that recognised the relationship between nature and humans and did not make a distinction between humans and ecosystems. As my close friend and marine sociologist Dr Philile Mbatha explains in our documentary film about the play:

‘In isiZulu, the word conservation doesn’t really exist. Historically, people never felt that they needed to conserve nature. A lot of political ecology literature talks about this idea of conservation as having emerged in the industrial period, where humans wanted to create sanctuaries of nature to escape to, which then became nature reserves. But in many parts of the Global South, people have never seen this separation between humans and nature. It’s about them understanding nature and their feeling that nature also understands them. So this is one of the aspects that appears in the play, which I think is so powerful because it represents how many people in coastal areas in South Africa see their relationship to nature, and also in many parts of the Global South as well.’

Today, if a *sangoma* or *Nyanga* (traditional healer/herbalist/diviner) wants to go to the sea to perform rituals and make libations to their ancestors, or if a family wants to visit their loved ones’ graves on what had been ancestral land but is now fenced off in the iSimangaliso Wetland Park, they are chaperoned by park rangers armed with semi-automatic rifles. Indeed, during my time as a researcher at the One Ocean Hub, we witnessed the killing of two brothers by park rangers for fishing in coastal waters where their people had won a land claim. The region still grapples with this legacy, demanding imaginative leaps, empathy, generosity and renewed ties between conservation and culture – bonds that colonialism and old scientific dogma poisoned, fracturing *ubuntu*-based care.

In this spirit, I draw on the collective of colleagues and friends like Dr Taryn Pereira and the Coastal Justice Network, where over the past six years researchers, civil society partners and small-scale fishery leaders have documented the ongoing historical and contemporary exclusion of coastal communities from ocean governance and access to their customary territories. Through the collaborative citizen-led creation of our Empatheatre play *Lalela Ulwandle* and film *Indlela Yokuphila*, we’ve uncovered how deeply the ocean is woven into cultural heritage, identity and spiritual belonging for coastal people.

Perhaps the most mis-narrated and failed conservation storytelling to date in South Africa is how we frame and narrate fishing, especially the struggles of small-scale fishers. For many of these fishers, fishing is

not just a livelihood; it’s a way of life. It is heritage. It is survival. In South Africa, small-scale fishers are systematically marginalised, their customary rights overruled by conservation enclosures, mining interests and white-dominated recreational fishing that continues with impunity. Despite clear evidence that the recreational fishing sector contributes more to illegal fishing infractions than small-scale fishers do, conservation storytelling still too often lumps artisanal fishers in with the impact of industrial fleets.

Indeed, even our conservation education uses terms like ‘ocean literacy’, which implies and assumes that the ocean and the care for it is something that needs to be taught or explained away. Having spent time with small-scale fishers over the past six years, I learned quickly that they are more than ocean literate; they are ocean fluent. And they have much to teach marine scientists, marine protected area managers and policy-makers alike. Small-scale fishers globally play a critical role in defending oceans from a variety of pressures and, as part of the Ocean Defenders Project, they are working together to protect them.

At a local level, it was small-scale fishers who bravely took oil and gas giant Shell and the South African government to court, challenging their plans to explore for oil and gas offshore. Our radio play and short film were used as evidence in court to support their testimonies. Yet even after this heroic ‘David and Goliath’ story, fishers are still persecuted and vilified, and often treated in patronising, and sometimes violent, ways by conservation systems. The Green Connection and Natural Justice

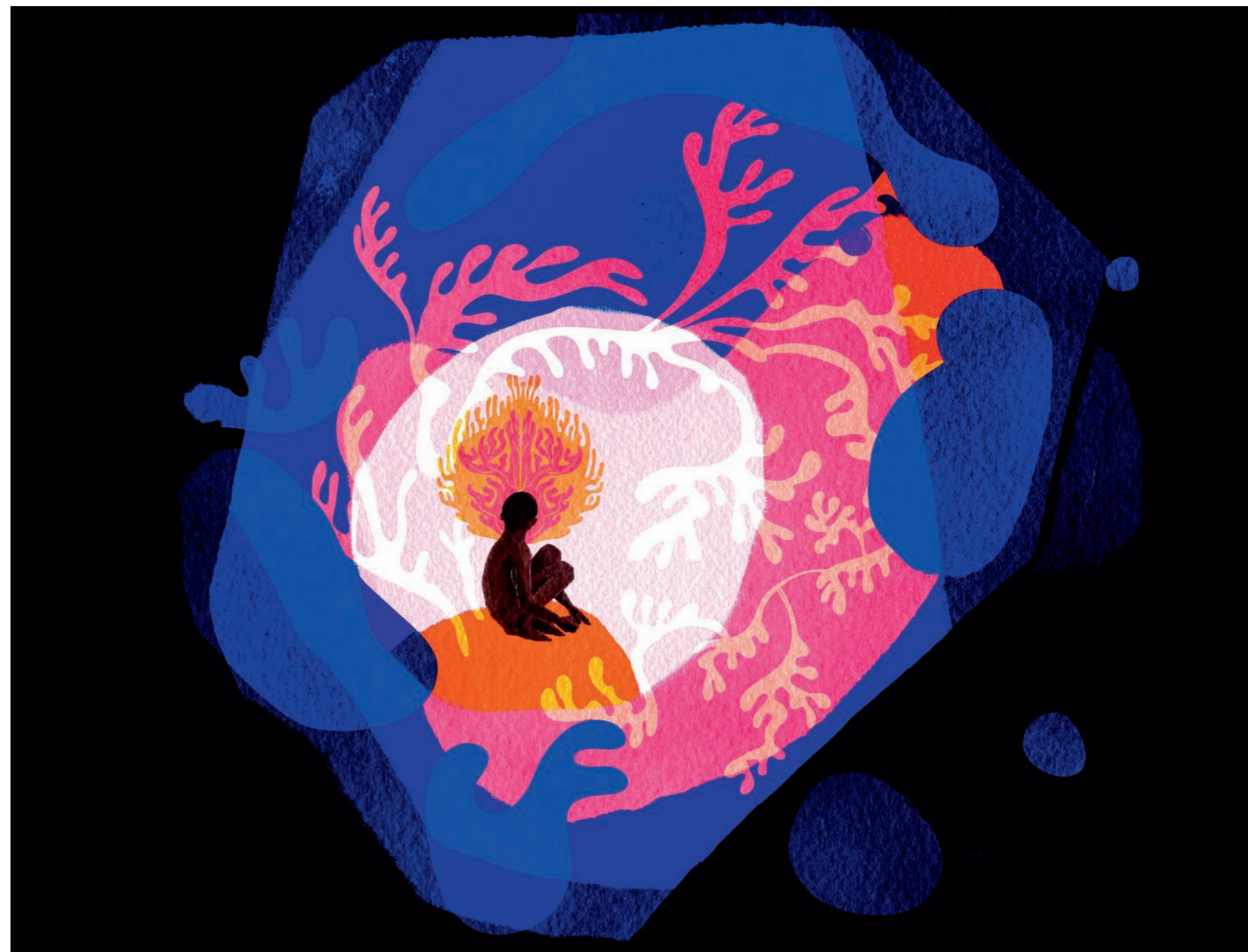

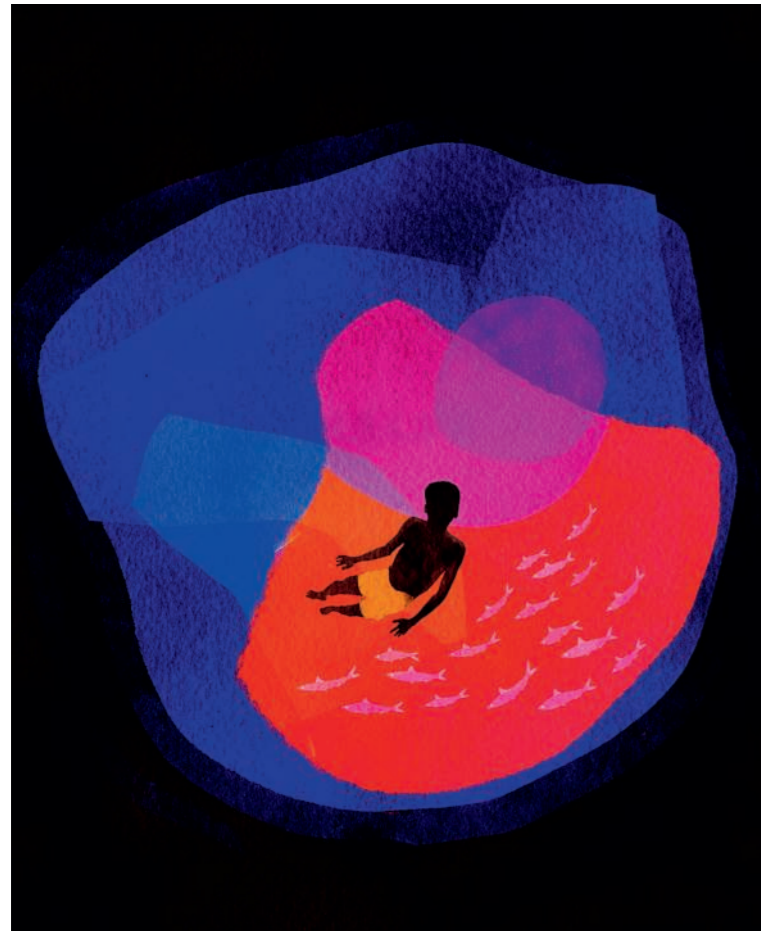

recently won another case, against TotalEnergies and Shell. Citing earlier victories led by small-scale fishers, the High Court ruled that a previous authorisation for offshore drilling was unlawful as it ignored, among other issues, the rights of coastal communities.

Donna Haraway reminds us that it matters whose stories, whose worlds get to accompany the conservation sphere in South Africa today. Who gets to practise natal-homing and who does not? These are contradictions of light and dark, of high tide and low tide, that we are having to navigate. It was questions such as these that I grappled with in curating the exhibition. How, I wondered, do we not drown in the contradictions of conservation care for turtles and care for the justice of South Africans?

By working with artists, fishers, sociologists and scientists, I learned to narrate this contradiction by borrowing the concept of 'shimmer' from anthropologist Deborah Bird Rose. Drawing on Aboriginal wisdom, Rose describes shimmer as the dynamic, entangled, ever-changing interplay of humans, animals and environments. It resists Western dualisms – human/nature, culture/ecology, politics/turtles – reminding us that relationships are fluid, indeterminate and in constant motion. Shimmer asks us to respect interconnectedness and to challenge the colonial constructs of 'wilderness' and 'nature'. Shimmer helps us shift away from assumptions or colonial misconceptions (or propaganda) of 'wilderness'. A wilderness was never an empty space; it was the homeland of indigenous people but was declared *terra nullius* to justify conquest. Even today, conservation terms like 're-wilding' risk repeating such erasures. Shimmer instead invites us to recognise our place within ongoing and entangled worlds, rather than imagine a return to some untouched past.

What does conservation storytelling look like when we step away from words like 'wilderness' or 'nature' – or 're-wilding' – and remember that people are part of nature too? What does it look like when we write

ourselves back into earth communities? As I have learnt from Dr Mbatha, when white settlers arrived in Kosi Bay, they looked at the estuaries and wetlands and saw wilderness; not the ancient *amadobo* systems of farming the wetland. So deeply were these systems integrated into the ecology of the wetland, they were invisible to the colonial gaze. In what other ways have we been unable to see? In what ways are our stories solidifying what feminist and political scientist Joan Tronto calls 'privileged irresponsibility'?

In making *Umkhosi Wenala*, we learned the story of what it was like for fishers before the fences. When they wanted to fish in the estuary they would stand on the shore singing and clapping a particular rhythmic song – a song for hippos. Habituated over generations, the hippos knew it was time to move to the other side of the estuary and they would migrate, followed by the crocodiles, which were made nervous by the rapid and sudden migration. This ancient system of 'speaking with' the more-than-human world, through music and customs, meant that there was no need for fences. Embedded in these songs and customs were also forms of governance and environmental custodianship and care that modern conservation still overlooks.

As we tell new conservation stories and as we educate new generations of marine scientists, we must ask ourselves: are we merely conserving species or are we also conserving colonial legacies of blindness, of privileged irresponsibility, of erasure? What might we be missing when we ignore customary lore and laws, when we overlook stories, songs, dances and cultural practices? What wisdom are we missing?

I long for a reparative conservation storytelling ethic, one in which we decolonise conservation and centre the perspectives, voices and legacies of those who have been its casualties. A storytelling ethic that re-orientates conservation towards care that is relational, accountable and locally rooted. And one that brings to the surface the wisdom of local traditions of care, conviviality, communion and reciprocity.

The small-scale fishers who took Shell to court; the healers fighting for spiritual access; the children growing up on coasts still marked by the geography of racial exclusion – these are the ocean defenders we must honour in our storytelling.

To borrow the thinking of Thom Van Dooren, a professor of environmental humanities, what does conservation as a multi-faceted, always compromised work of inheritance look like? If we were to think along the same lines as small-scale fishers, scientists, children, *sangomas*, holders of customary rights, educators, philosophers, ghosts, turtles, swimmers, surfers and their worlds, how would that help us be truer to a multi-species kin-making ethic? How could that shape our approach to conservation here and now?

For many marginalised communities that have been displaced through colonially rationalised conservation, 'protecting the turtle' can be seen as a Trojan horse; conserving turtles facilitates further loss of land and rights. Because of this, these communities cannot value and cherish biodiversity in the same way as conservationists have been trained to do. A conservation legacy is a weighted symbol, a powerful enabler of a broader colonising process, a broader fracturing of community and *ubuntu*.

We need an expansive, recurring and politically rigorous approach to conservation storytelling – one that refutes the false promise of scientific objectivity alone – when our research causes social harm or reinforces immoral legacies of power. Thinking at this level of complexity with fellow artists and activists – as I ended up doing in relation to the exhibition and in our plays and films – opened us up to useful questions: what do we hold on to and what do we let go? What must we remember and what might we remake anew? Who gets to tell these stories? And who creates opportunities for knowledge holders to tell their own stories?

For me, the answer lies in letting people tell their own stories or learning how we might work in solidarity to help bring their stories to the surface. I am learning from ocean storytellers and world makers like Dr Joanne Peers, who is collaboratively sculpting ocean education despite, and because of, our oceans' haunted history. I am learning from Dr Aaniyah Martin, who is using storytelling to build care pedagogies and practices for new kinds of ocean custodianship. The incredible Traci Kwaai, a 'fisher child' as she calls herself, who is decolonising and reshaping how we remember and tell stories about the False Bay coastline. Shamier Magmoet, a National Geographic explorer from the Cape Flats who is reclaiming the ocean for his community and neighbourhood and inviting other worlds into his own. Dr Nasreen Peer, a marine scientist who knows what solidarity science looks like and is nurturing a future generation of scientists who are attentive to how their stories shape worlds. Dr Philile Mbatha, who is helping displaced communities from the ocean to reclaim their customary

governance systems through their stories. Dr Loyiso Dunga, a scientist and the grandson of a *sangoma* who doesn't accept that these two worlds need to be contradictory and is mapping and bringing to the surface bio-cultural stories of the ocean. Dr Taryn Pereria, who is co-creating 'in movement' ethics and ways of solidarity storytelling. Or my beloved sister and brother Mpume Mthombeni and Neil Coppen, co-founders of Empatheatre. They know the power of stories and understand the responsibilities we have when we are gifted other people's stories and mandated to share them in meaningful ways. If you need a lesson in conservation storytelling that is course correcting, read and watch their stories.

What I learned in my storytelling practice, in this exhibition and in my theatre- and film-making with others, is to not just ask what is the turtles' story, but rather, what is the story of the world that the turtle comes with?



Africa Refocused

WORDS BY

Lauren De Vos

In conversation with Noel Kok, co-founder of Nature, Environment & Wildlife Filmmakers (NEWF) and National Geographic Explorer (Africa Refocused is a collaboration between NEWF and the National Geographic Society).



Rebecca Hale | National Geographic

'Every time you saw a story on Africa, we Africans were portrayed as the poacher, the pirate, the ranger, the guide, or the singing people welcoming you at the entrance to a national park.' Noel Kok and Pragna Parsotam-Kok started Nature, Environment & Wildlife Filmmakers (NEWF) to flip the script; African natural history and conservation stories, they believe, can be told by an international network of professionals led by indigenous African storytellers and scientists. Lauren De Vos chatted to Noel about breaking barriers, cultivating community and building a fair platform for Africa's offerings on an international stage.



Anthony Ochieng Onyango | National Geographic



Anthony Ochieng Onyango | National Geographic

My journey started when I was seven years old, playing outside a shopping centre in Pinetown, KwaZulu-Natal. A lady and her child walked past; I smiled and greeted them. They packed their parcels into their car boot and as they drove away the lady wound down her window and handed me 20 cents.

You know they say that when you first see a rhino, that moment will stay with you forever? That was when I first saw a rhino: the car's bumper sticker said, 'Save The Rhino'. This was the late 1970s in South Africa. The lady and her child were white. As a kid, I noticed that whenever I saw this sticker, the car's occupants were always white.

You went on to have a career in the South African film and media industry, but not initially in natural history. What changed?

Many years after I saw that rhino bumper sticker, I looked for the real animal on a holiday in the Kruger National Park. I understood the hype once I saw it, but variations of the stereotypes I'd grown up with were everywhere: I was the only person of colour on holiday in the park. Whenever I saw conservation on television, the person of colour was the ranger, guide or labourer.

Decades later, film and television were booming across Africa, but why not in the natural history genre? One day, I landed at Oliver Tambo International Airport in Johannesburg and saw my third rhino: a bedazzled statue raising awareness for the renewed poaching crisis in South Africa. I thought, 'Poaching is back, but this rhino is in the wrong place if we want to stop it.' Then and there, I wrote a concept for an African nature television series, told in Zulu.



Anthony Ochieng Onyango | National Geographic

But in 2015 it was unbelievably challenging for us to access South African scientists, particularly black researchers in the national parks. We produced the film, but it nearly broke us. African nature storytellers were rarer than some of the species we were trying to protect. I like to say, 'How do you change the story? You change the storyteller.'

But Africa's natural history storytellers did exist. Were we just not hearing their stories?

Absolutely! I believe that Africans – whether Zulu, Afrikaans, Ghanian or Nigerian – are storytellers. So much of our history has been told orally. Whether you are a *tannie* from the Karoo or a scientist in Benin, there is a tradition of storytelling that you carry with you.

So you moved from making your own film to creating a space where hundreds of others can craft their own?

There were two original impetuses to move on from creating that Zulu-language show to starting NEWF, which was a vehicle to address what we'd discovered was obstructing us in our original film goals. Firstly, African stories and storytellers existed, but they didn't have the platform to share those stories. People didn't know the value of their stories or didn't know that there would be an audience if they told their stories in their own languages. Secondly, the representation of Africans within the existing natural history and conservation storytelling genre was limited to stereotypes.

Your work has evolved to include building community and creating access. Would you say that at each stage you realised you must go deeper to dismantle the fundamental hurdles?

Initially we needed to create a groundswell to say, 'Hold on, Africans have always told stories, and they hold generations of ecological knowledge. We just need the trust of the sector to bring these voices into the fold to tell their own stories – and to tell new stories too.' Our inaugural 2017 NEWF congress and four short films by young, emerging African film-makers created a buzz, just enough for film commissioners to realise that there are storytellers in this space.

But we couldn't succeed with just an annual congress. The barriers to entry were so institutionalised that we needed to find a way to dismantle them. We started NEWF Labs to target what was keeping people out in the first place.



Anthony Ochieng Onyango | National Geographic

Stories of African wildlife on land abound, but our oceans seem further out of reach. Why was this important to reframe?

Africa is surrounded by more than 30,000 kilometres (18,600 miles) of coastline and 38 of the 54 countries have a coastline. What stories were being told by Africans about our ocean? How were we getting involved to protect the ocean?

At our 2018 NEWF Congress, we wanted to put a black African underwater film-maker on the discussion panel – and it was like searching for a unicorn. In the process, we met hundreds of African marine scientists who could not dive or swim. There was a generation of marine biologists emerging – a fantastic thing – but they had never laid eyes on the habitats or species they were studying. In response, we started NEWF Dive Labs.

NEWF has trained hundreds of African divers from your base in Sodwana Bay. This in itself seems like a story to share?

We now have our own storytelling, research and dive centre. We are officially a PADI university, and we have a community across Africa of over 360 Fellows from 34 countries. And 192 of them are certified divers, including 12 dive instructors, 20-odd dive masters and divers across various levels. There are Fellows who are also National Geographic Explorers, training their own cohorts of divers in Cameroon, Ghana, Tanzania. We're also starting programmes in Benin and Nigeria.

We started telling the stories of the ocean *and* our Fellows. We brought scientists and storytellers together to speak of the places and animals they are studying, and their journeys.

It must be huge to go from a desktop computer to a fully qualified diver!

We face so many barriers to entry. Across Africa, many people fear the ocean. In many places, this has become part of the folklore. My surname is Kok and I come from a KhoiSan background. I grew up terrified of the water because my father told me that his brother was taken by a mermaid. Our parents told us these stories to protect us if there wasn't money, time or the expertise to teach us to swim, and to keep us away from what could harm us. But even further back than that, some of this fear – we believe – stems from the slave trade. It was the water that took our people. And so these stories that were there to protect have been carried for generations.

Making underwater films is expensive. Is the cost prohibitive for someone starting out?

It's cheaper for us to fly Fellows from across Africa to be dive certified in South Africa than in their home countries because everything here is geared towards tourism. Diving and the ocean drive the economy where we are in Sodwana Bay, but even here

we have no South African black-owned dive entities, boats, nothing. Why is it that for Africans the ocean can only be for food or spirituality, not leisure or serious economy? Time and money are major barriers to entry. It is incredibly difficult for black Africans to have capital upfront for certification and gear, which keeps us from getting a foothold in ocean-related industries beyond being labourers or desktop scientists.

After the initial investment, you must encounter the stress of graduates finding work to repay their time, qualifications and gear.

Finding a job after acquiring the skills is probably the biggest barrier to entry into the world of conservation, storytelling and science. Often, emerging talents are pushed into a conservation sector that is still operating on a broken funding model where voluntourism can push out local graduates who need to be paid to work, not pay to work. This is something we need to urgently re-think.



Anthony Ochieng Onyango

There is a refrain that repeats across much of your Fellows' work: I am the first. The first in my family to swim. To dive. To study. To film. How does this show up?

I asked one of our marine biologist Fellows what her biggest challenge was and she said, 'The Christmas lunch table. I go home and no one in my family can understand what I'm talking about. It's the loneliest place for me. Because I am the first. I am the first in everything I do.'

This is why we were so focused on building community. We try to say that it's okay to feel a lot of the heavy stuff of being first. Yes, being the first comes with a sense of responsibility and loneliness, but it's also not your fault or burden. And here, there is understanding and support.

Anthony Ochieng Onyango

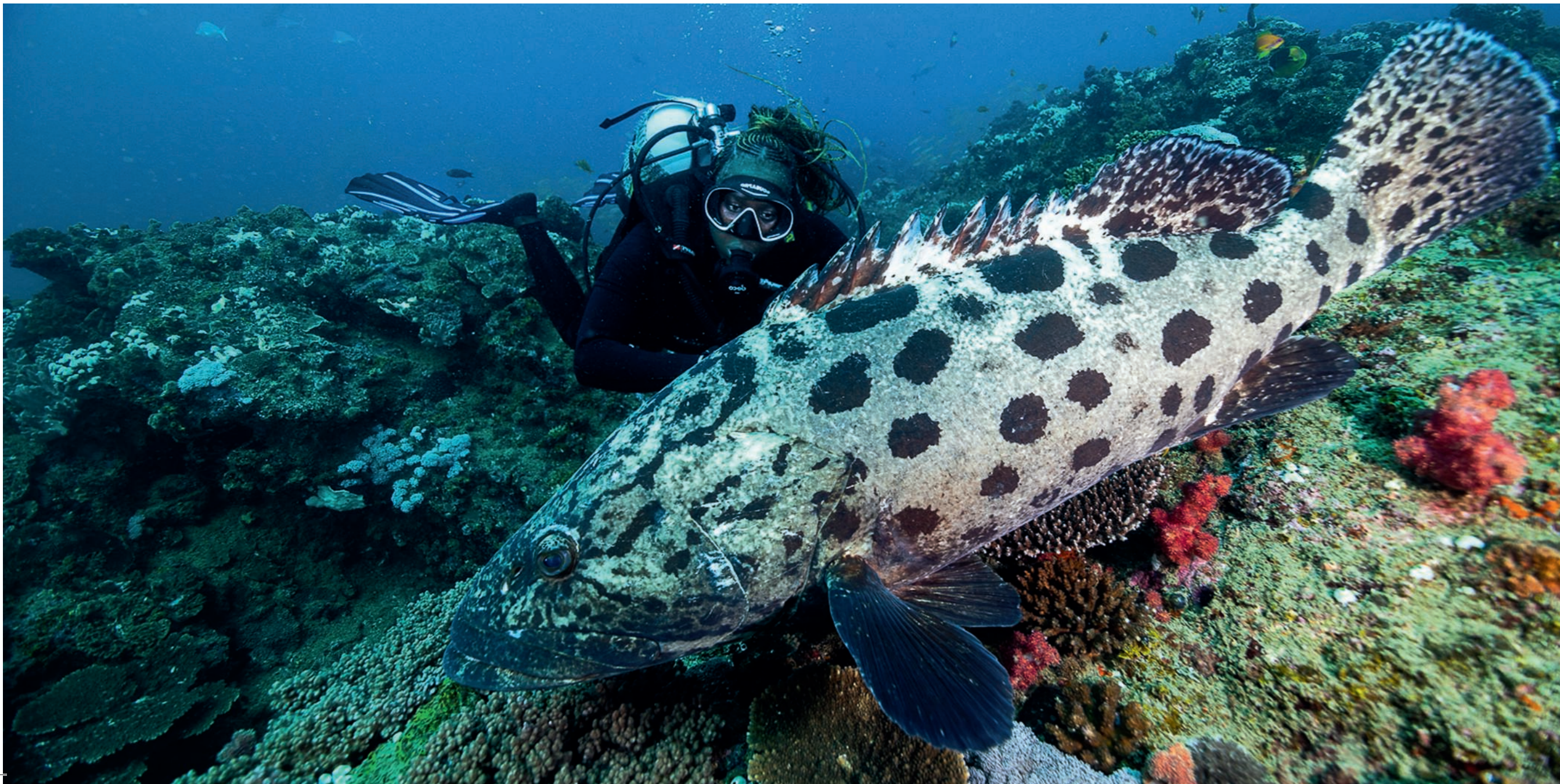

How do we mentor African storytellers while nurturing their own perspectives?

It's important to realise that there are many reasons why Africans want to be part of the industry and there are many ways that they each want to interact with the industry, too. Some want to travel and take on international jobs; they want to join the big networks and established broadcasters. There are others who want to run projects in their home countries, lead scientific research or tell African stories for African audiences. We want to normalise that all of these are valid choices. The point is to make these pathways realistic options for African storytellers.

How can African-led stories reach an international ear?

As Kaitlin Yarnall, National Geographic's chief storytelling officer, always tells us: everything comes down to purpose and audience. What is the purpose of that story, and who is its audience?

There are many instances where we can create a project that features an African scientist, that features African conservation work, that even uses a local language – but the narrator has, for instance, an American accent. To tell that story, we must accept that these are the parameters within which we must work. That's okay when we (Africans) are not the audience. It makes sense to speak to Americans in a format that they will best receive the story's message.

You mentioned that media were booming across Africa, but not in the natural history genre. Is this the other gap – creating, and reaching, an African audience?

Absolutely. When we're telling our own stories we have an opportunity to produce our own film and there is freedom in terms of how we frame it. That's when we can start developing an African audience; we can tell stories the way we, as Africans, want to tell them. The way our elders have passed down stories over generations follows the same storytelling structure as most other cultures. Find a central character that you can make relatable, add a major challenge or a quest, plot some twists and turns, and then rest in a resolution. Our ancestors have been using the same format as National Geographic and the BBC!

There's a balancing act between sending African stories out into the world and developing an audience on the continent. What's the common thread?

Who is the expert? Who is the genuine authority to inform the story? We recently made a film for an American audience that featured a black African scientist. In the past, an international production company would have picked a white international scientist to relate that story. Today we're saying no – *this* is who is front-facing, *this* is who will tell that story – even if it's for an international audience. We can make the story so much richer – and we can make the research so much deeper – when we genuinely collaborate.



ABOUT THE SAVE OUR SEAS FOUNDATION

The Save Our Seas Foundation supports scientific research and conservation efforts to better understand our oceans, and we invest in education and storytelling as the most powerful way to inspire action, and bring about sustainable and effective change. From its origins funding just five projects over 22 years ago, the Foundation now supports over 600 research, conservation, education, and impactful communication projects in more than 100 countries worldwide, all focused on threatened marine wildlife and their habitats.

To find out more about the Foundation, visit saveourseas.com

Editor-in-chief

Jade Schultz

Editorial team

Thomas Peschak, James Lea, Sandrine Griffiths, Julia Dufour

Copy writer

Lauren De Vos

Sub-editor and proof reader

Leni Martin

Design and art direction

Kelsey Lee Manners Dickson

Published by

Save Our Seas Foundation
Quai du Mont-Blanc 21
CH-1201 Geneva | Switzerland

Reproduction

Resolution Studios
1st Floor 8 Briar Road
Salt River, Cape Town

Printing

Polygravia
Route de Montreux 151
1618 Châtel-St-Denis, Switzerland
Printed 2026

ISSN (Print) 2296-8199
ISSN (Online) 2296-8202

*Back Cover: The Founder of the
Save Our Seas Foundation, dives
with silky sharks in the Red Sea.*
Sebastian Staines | © Save Our Seas Foundation



**"AS LONG AS THERE ARE PEOPLE
WHO CARE AND TAKE ACTION,
WE CAN AND WILL MAKE A
DIFFERENCE"**

THE FOUNDER | SAVE OUR SEAS FOUNDATION